



Solutions for commercial construction

Individual and sustainable
system solutions and services

heroal

Spaces for life, individual and sustainable.



Dear Readers,

Construction projects are becoming more and more complex, and the increased requirements for building shells require intensive cooperation between manufacturers, fabricators, architects, planners and investors. With recyclable systems made from recycled materials, minimal energy consumption in production and maximum energy efficiency during use, heroal system solutions make a decisive contribution to sustainable construction. heroal's Project Services are there to support you in the integrated planning and implementation of sustainable building projects.

In the first section of the brochure, you can find out more about heroal (from p. 4) and our Project Services (from p. 10).

The second section gives you an overview of the heroal system portfolio (from p. 26). In the third section, we present reference projects from all over the world (from p. 98) – from single-family homes and apartment buildings to commercial properties and hotels to special construction projects.

As a company, heroal stands for innovative, perfectly customised system solutions for the creation of individual living spaces whose functionality and design are thought out down to the last detail. Our architectural consultants and the heroal Project Services team are happy to advise you – naturally also right at your construction site.

The heroal team



heroal

- 04 About heroal
- 154 Contact

Services

- 10 Project Services
- 20 Sustainability
- 16 Quality
- 18 Design
- 24 Special solutions

Systems

- 26 Window systems
- 36 Door systems
- 46 Lifting-sliding systems
- 54 Curtain wall systems
- 62 Non-insulated profile systems
- 68 Sun protection systems
- 76 Roller shutter systems
- 82 Roller door systems
- 90 Roofing systems

References

- 98 Education & Science
- 106 Office & Administration
- 120 Hotel & Residential
- 132 Industry & Trade
- 144 Culture & Entertainment
- 146 Project-specific testing
- 148 Special solutions

We create spaces that enrich life.

heroal is an international market leader in the manufacture of aluminium system solutions for roller shutters, sun protection, roller doors, windows, doors and curtain walls. Founded in 1874, the family company has over 800 employees at its head office in Verl, Germany and other sites in Europe and is involved in the construction of sustainable residential and commercial buildings worldwide. For heroal, the focus here is on creating innovative and high-quality complete solutions for fabricators, architects, planners, investors and building owners marked by first-class quality, industry-leading customisation options as well as consulting and services in every phase of the building life cycle.



Why heroal?

Sustainable

Our top priority is our responsibility for our employees and the region as well as using durable, recyclable systems made from recycled materials for sustainable buildings.

High-quality

heroal systems for building shells, interiors and exteriors are manufactured 100% in Germany and are adapted to meet the specific needs of our customers and partners.

Reliable

In our state-of-the-art 40,000 m² logistics centre, all heroal systems are centrally stored, picked and delivered to our customers with our own fleet of trucks.

Individual

heroal systems stand for customised solutions of the highest quality. Our in-house surface coating and profile bending and folding technology open up a limitless variety of designs and colours in highly weather-resistant quality.

Unique

Thanks to its cooperation with Les Couleurs® Le Corbusier, heroal's systems can be coated exclusively in these unique colours.

Everything from a single source

heroal supplies everything from a single source for an essential portion of the building shell, ensuring easier planning and tendering as well as colour-coordinated systems.



Scan and view film

Innovation and quality “Made in Germany”.

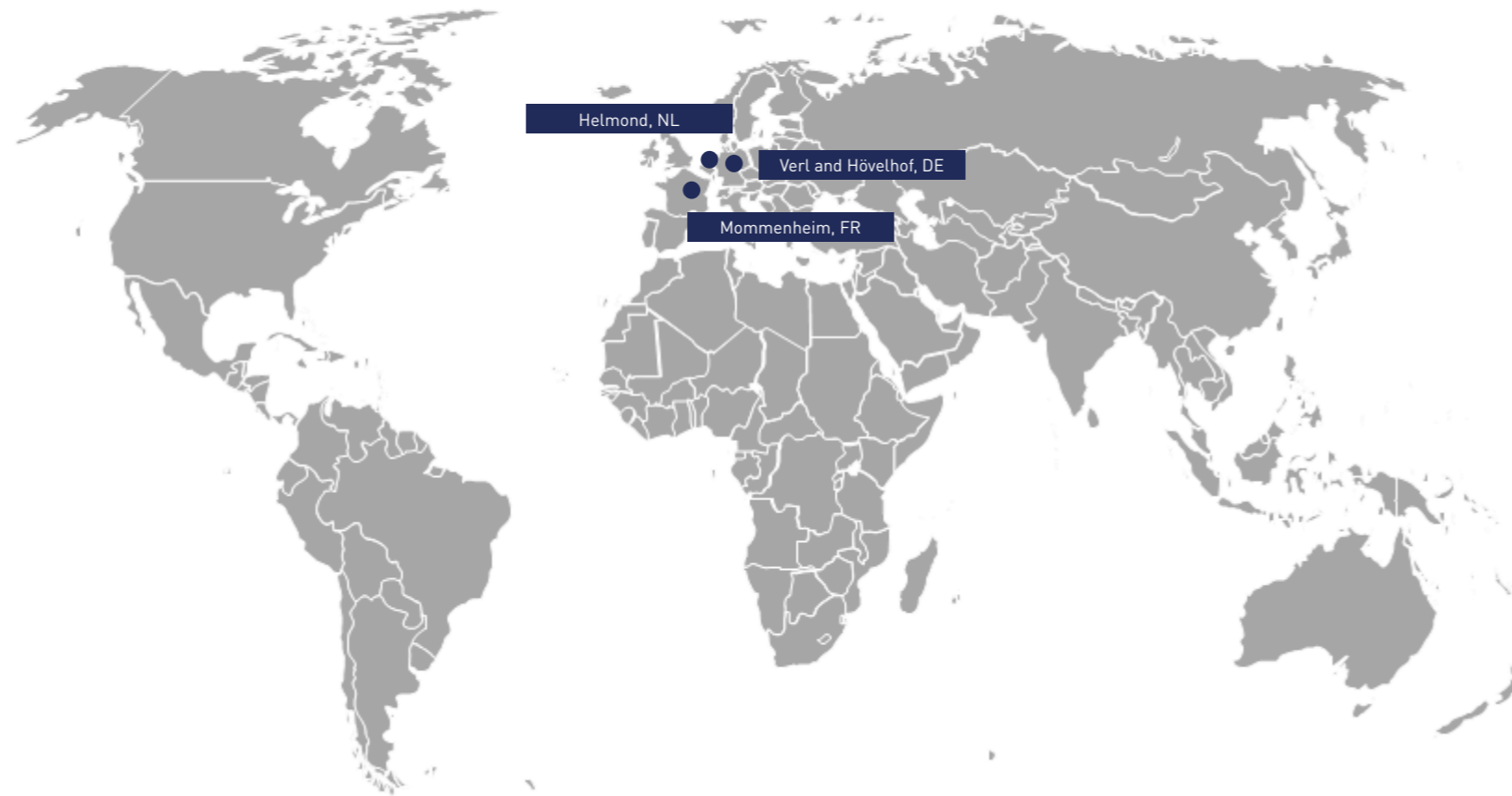

Plant I und Administration, Verl, Germany



Plant II, Hövelhof, Germany



Plant III, Hövelhof, Germany

Plant I, Verl, Germany

Our site in Verl is home to Plant I, where roller shutters, roller doors and sun protection systems are produced. Our machine and tool construction facilities, training centre, administration and a showroom are also located at this location.

Plant II, Hövelhof, Germany

Plant II in Hövelhof is where we produce window, door and curtain wall systems. Our coating systems and quality line are also located in Plant II.

Plant III, Hövelhof, Germany

Plant III is our logistics centre in Hövelhof. We deliver all systems to our customers from here.

Distribution sites

Our distribution sites are located in Helmond (NL) and Mommenheim (FR).

Showrooms

In Verl (DE) and Prague (CZ), you have the opportunity to experience heroal systems and services live.



Distribution site Mommenheim, France



Distribution site Helmond, Netherlands



Showroom, Verl, Germany



Showroom, Prague, Czech Republic

Innovation meets tradition.

1874 Johann Henkenjohann sets up his own business producing clogs, thereby laying the foundation for the company.

1948 His grandson Johann Henkenjohann takes over the company in its third generation. A few years later, he begins with the production of wooden and plastic roller shutters.

1964 Johann Henkenjohann turns to aluminium as a material. To give them greater stability, the aluminium strips are roll-formed. During this time, heroal also begins to manufacture roller doors.

1969 Johann Henkenjohann invents the foam-filled aluminium roller shutter slat and revolutionises the roller shutter market with "heroal Selecta".

1975 heroal expands its portfolio to include windows and doors. The next few years see the further addition of curtain walls and lifting-sliding systems.

1982 With Plant II in Hövelhof, heroal further expands its production capacities.

2009 Dr Vera Schöne, Johann Henkenjohann's daughter, becomes Managing Director.

2011 heroal uses its own fleet of trucks to supply customers with products from its 40,000 m² logistics centre (Plant III).

2015 heroal expands its portfolio to include sun protection.

2015-2017 heroal opens further branches.

2017 heroal puts its quality line (Plant II) into commission, offering fully automated quality control.

2019 The new company building, the heroal Forum, combines a bistro, training rooms and offices.

2020 Dr Max Schöne joins the company management in the fifth generation.

2022 heroal opens showrooms in Prague (Czech Republic) and Verl (Germany).

2024 heroal celebrates its 150th anniversary.



Innovation Award Architecture + Building 2023 for the heroal D 72 PF EM door casement profile
The front door variant heroal D 72 PF EM was awarded the 2023 Innovation Award for its optimised production time and faster and simpler infill panel installation using clips, which dispenses with the bonding of panels.



German Design Award 2021 for the heroal OR outdoor roof system



R+T Innovation Award 2021 for the clamp-on sun protection system heroal VS Z EM

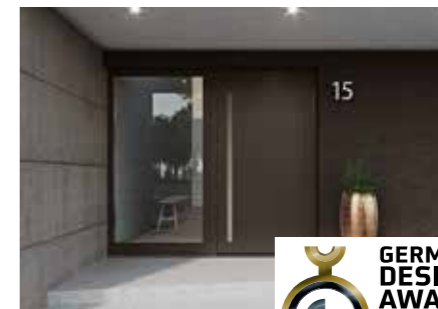

German Design Award 2020 for the heroal Les Couleurs® Le Corbusier front door



German Innovation Award 2020 for the heroal S 65 sliding system



Architect's Darling Awards 2019 for the heroal DS drainage system



Green Good Design Award 2019 for the AFI Vokovice, Prague

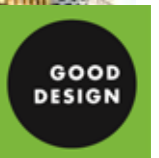

Support in every phase of construction planning.

Interview with Ronny Symannek, Head of Project Services & Quotation Centre



You are the head of Project Services. What tasks are you and your team responsible for?

heroal Project Sales is set up like a classic sales organisation, with field and inside sales. My team and I are responsible for the internal structures, and here we work closely with the field sales team of Project Sales, which maintains contact with our partners and those involved in projects in various markets. Our key function is to advise and support architects, specialist planners and investors in all phases of project planning. Our service portfolio includes a number of different services that we offer free of charge, including static pre-dimensioning, preparing design proposals and calculations, and drawing up contract specifications.

Where does the advisory function of Project Sales typically set in?

As a matter of principle, our advice is individually tailored to each architect, specialist planner or investor. Together, we look at which planning phase our contact is in at the particular point in time and consider how we can best support them in their situation. This makes each enquiry different, sometimes only requiring selected services from our range. However, we are often called in early on, for example in the pre-planning or design phase, in which case we offer advice in system selection. The aim here is to find the optimum system combination based on the given requirements – one which satisfies all the specified requirements for heat insulation, noise insulation and burglary resistance. For this purpose, we carry out structural assessments

and static pre-dimensioning. We are also responsible for the development of special solutions if this is desired or technically necessary for a project. This reduces the workload of the trades involved in planning considerably, as they are often not as deeply familiar with our products as we are and would need to invest a lot of time to carry out the system selection process at this level of detail.

After making the ideal system selection, what is typically the next step?

On the basis of the system selection, we next draft design proposals and drawings for the detailed design plan required for the further planning process. These are already based on the concrete pre-dimensioning. This service saves architects in particular a great deal of time and money, as they do not have to consult a specialist planner for complex planning situations, but instead receive a proposal from us whose technical feasibility has been verified.

Preparing the contract specifications also takes up a lot of resources for the trades concerned with planning. What support do you offer for this work step?

In this step, we respond flexibly to the needs of architects. If they create the contract specifications themselves, we provide them with the necessary tender texts. Alternatively, we can also take charge of creating the entire project-specific contract specifications.

Project Services also include the preparation of quotations for fabricators. What added value does this offer architects?

Depending on the scope, preparing a quotation can be a very time-consuming and complex task, as there are often many details to consider. We support our fabricators in the preparation of quotations, making it easier for them to submit a quotation. We stay in close contact with our fabricators at all times and can also meet them at the project site if required. Because we take a lot of work off the fabricators' hands, it is much easier for them to submit a quotation. The advantage here for architects is that this increases the choice of bidders.

In the scope of the order process, we also assume responsibility for preparing project-specific verifications, such as testing the tightness against driving rain in the case of special constructions. If the verifications are to be provided by an external, accredited testing institute, we are also there to support this process.

Ultimately, we offer consulting during almost all project planning phases and are always available to advise architects, specialist planners and investors as a competent partner.



Scan and view film



Scan and view film



Sustainability in practice at heroal.

As a manufacturer of innovative, high-quality aluminium systems for roller shutters, sun protection, roller doors, windows, doors and curtain walls, we place great value in taking a holistic approach to sustainability. This applies not only to our systems, which boast exceptional durability and energy efficiency, but also our state-of-the-art production facilities and our entire supply chain. We use recycled, reusable materials to ensure a closed-loop material cycle. Furthermore, certifications help to make the construction process secure and transparent. We are also actively committed to the environment, our employees and the region. In this respect, we are aware of our social responsibility, which we are happy to assume as a company with roots in the region.



Build sustainably Products

High resistance to weathering, natural protection against corrosion and high material stability make aluminium systems extremely durable. We use alternative, environmentally friendly technologies and materials: in addition to the resource-conserving use of materials, a closed-loop material cycle is crucial. This is why we use up to 85% recycled aluminium for our products. This means 95% less energy consumption compared to new aluminium without compromising on quality. The PU foams used for foam filling for the modular insulation zones of the aluminium profiles are produced without halogenated blowing agents. Thanks to their modular construction, heroal systems can be individually adapted to the heat insulation requirements of different building projects. Thanks to the innovative heroal sealing technology, high-insulation profiles for use in passive houses and optimum U-values, heroal systems meet all requirements for energy-efficient construction.



ift Rosenheim EPD
For heroal window, lifting-sliding, door and curtain wall systems, partner companies can refer to the heroal Communicator or the ÖKOBAUDAT database to view the EPDs for frame profiles and defined sizes and can use an order form to have these customised.

Plan sustainably Building certifications

High-insulation, recyclable systems made from durable materials create the conditions for energy-efficient construction and certifications for building projects. In order to acquire building certifications such as DGNB, BNB, LEED or BREEAM, internationally recognised environmental product declarations (EPDs) help to demonstrate the sustainability of our products. EPDs are available for heroal window, door, sliding and curtain wall systems.



Sustainably certified Cradle to Cradle Certified® Silver

Certification according to Cradle to Cradle Certified® attests to the comprehensive sustainability performance of products along the entire product life cycle. This internationally recognised certification considers, among other criteria, the secure and potentially infinite circulation of materials in cycles and serves as a verification document in many green building standards, such as LEED or WELL. A total of 36 heroal systems from the areas of window, door, curtain wall, lifting-sliding door and fire protection systems have this certification.

Assessment of heroal systems according to the 5 performance criteria

- » Material Re-utilisation: Gold
- » Renewable Energy & Carbon Management: Gold
- » Social Fairness: Gold
- » Water Stewardship: Silver
- » Material Health: Silver und Bronze (fire protection)

AUIF-certificate 2022
 heroal actively participates in a qualified material cycle for aluminium. This cycle recovers aluminium from capital goods for capital goods.



**Process sustainably
 Recyclable aluminium**

The recycling cycle for aluminium initiated by AUIF ensures the production of new high-quality aluminium profiles from scrap metal as well as adherence to efficient recycling methods. As a member of AUIF, we demonstrate our commitment to the closed-loop, resource-conserving recycling of aluminium by using recycled aluminium for our products. While other materials like plastic lose quality with each recycling process, aluminium is 100% recyclable. Moreover, the remelted aluminium is in no way inferior to the primary aluminium. After use, heroal systems can be returned to the recycling cycle.

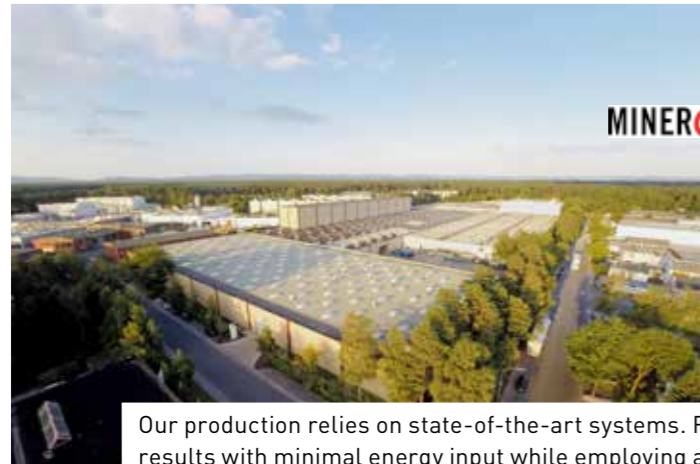

MINERGIE®

Minergie standard
 MINERGIE is a registered trademark for sustainable construction and has been the Swiss standard for comfort, efficiency and value retention since 1998

**Produce sustainably
 Production**

Our production relies on state-of-the-art systems. For example, we achieve premium coating results with minimal energy input while employing a coating cycle in which 95% of the profiles are coated with recovered powder. Improperly coated profiles can be easily recycled. For years now, we have used a chromium-free pre-treatment process for coating with no carcinogenic substances. To further increase sustainability in production, we have complete water treatment in our coating systems as well as an in-house combined heat and power plant, which generates most of the energy required for production. We have limited the consumption of packaging materials and use recyclable foils to package our products. We are continuously reducing the chemical waste generated during the production process and dispose of it in accordance with applicable guidelines.



**Think sustainably
 Society**

As an employer with roots in the region, the local population is particularly close to our heart. We support local foundations, aid organisations, cultural events, schools and sports clubs in the region financially or with donations in kind. We also support charitable initiatives and projects worldwide in the areas of education and science, ecology, development aid, social affairs, sport and health, and art and culture, including, for example, "Gola Forest Preservation, Sierra Leone", "Zambesi Forest Conservation REDD+, Zambia", the child aid foundation "Human Help Network e.V.", and the German charities "Herzenswünsche e.V." and "Aktion Kleiner Prinz Internationale Hilfe für Kinder in Not e.V.".

**Supply sustainably
 Supply chain**

heroal system solutions are manufactured at our German production sites in Verl and Hövelhof. This enables us to meet the highest quality standards and to ensure an efficient supply chain, as we coat our profiles in our own coating system and can then deliver them directly to fabricators with no additional transport routes. We also consider environmental criteria and responsible conduct when selecting and assessing our suppliers. For deliveries within Europe, we use our own fleet of trucks, which also satisfies the highest standards. For example, our vehicles all have Emissions Sticker 4.



**Work sustainably
 Employees**

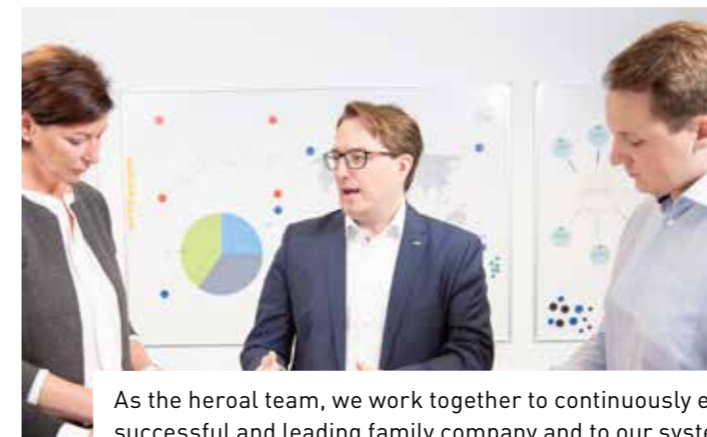

As the heroal team, we work together to continuously expand our market position as an economically successful and leading family company and to our systems to create spaces that enrich life and work today and in the future. We think in the long term and stand for stability, secure jobs and fair, respectful cooperation. We continuously invest in the training and further education of the heroal team, offer a modern working environment, flexible, family-friendly working time models and attractive benefits, such as health programmes, bicycle leasing and our heroal Bistro.

heroal quality - made in Germany.

heroal stands for high quality and produces exclusively in Germany. Our fully automatic quality control has established a new standard – 100% objective and seamlessly documented. Our profiles are foiled immediately after coating to ensure their optimal protection on the construction site.

We use our own coating systems to give the heroal aluminium systems surfaces that meet the most stringent international quality standards. They ensure high colour stability, protection against UV radiation, gloss retention and exceptionally weather-resistant surfaces. The high quality of the heroal coatings has been endorsed by numerous certifications, including the Qualicoat quality label and our distinction of being named an official GSB Premium Coater.



The heroal standard of quality also extends to its many years of cooperation with suppliers who are at the forefront of their respective fields as well as a high level of vertical integration, which we can only achieve by using machines developed in-house. These favourable conditions also enable us to quickly implement individual requests, which we can deliver to our customers with short turnaround times thanks to our reliable in-house logistics.

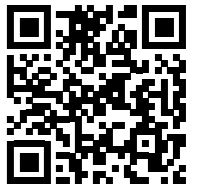

Scan and view film

Quality – layer by layer: the heroal coating process.



heroal hwr powder coating

Colour that just keeps looking good: The high-quality heroal hwr powder coating delivers top performance in terms of colour stability, gloss retention, weather resistance and UV protection. The coating powder is electrostatically applied to the pretreated aluminium profiles. The coating process naturally also satisfies all the ecological requirements.

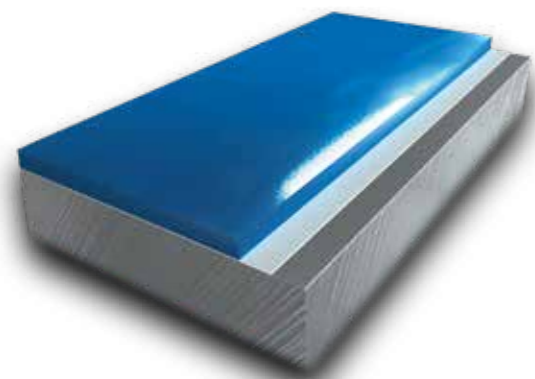

- Coating structure:**
1. Aluminium base material
 2. Chromium-free passivation
 3. heroal hwr powder coating

heroal Surface Design (SD)

Individuality in top quality: heroal Surface Design surface finishing lets you create stunning wood, concrete and rust looks. A transfer foil is used to burn the design structure onto the powder-coated profiles at 200°C in a vacuum process. The foil is then removed after the process. So the designs are permanently connected to the heroal hwr powder coating for a first-class surface quality.

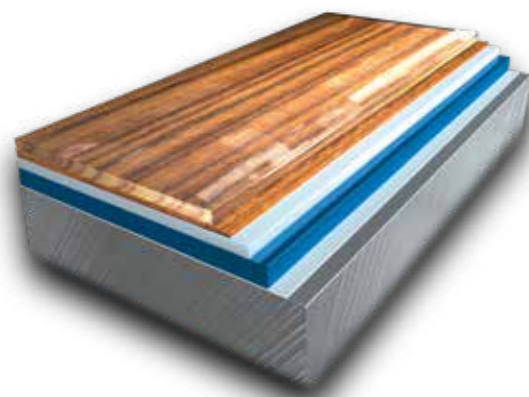

- Coating structure:**
1. Aluminium base material
 2. Chromium-free passivation
 3. heroal hwr powder coating
 4. Transfer foil with sublimation ink

heroal 2-layer thick coating

Ideally equipped against wind and weather: coating with heroal 2-layer thick coating gives roll-formed aluminium components special colour and weather resistance. The thick coating is applied in the rolling process and burned in at 240° C, after which a clear coat is applied and the aluminium is roll-formed. Quality that even certifies the thick coating for demanding maritime applications.

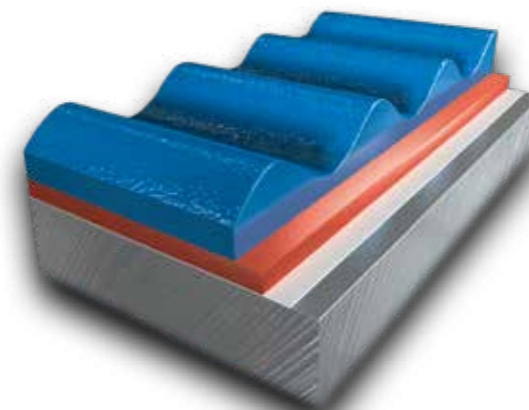

- Coating structure:**
1. Aluminium base material
 2. Pre-treatment
 3. Base coat
 4. Protective coat

heroal Eloxal coating

Elegant metallic look: Eloxal colours give extruded profiles a vibrant, metallic reflective surface. In the anodising process, the top layer of aluminium is converted into a defined aluminium oxide layer under the influence of direct current in an electrolytic bath. For better reproducibility and weather-resistance, Eloxal colours can also be created with heroal hwr powder coating.

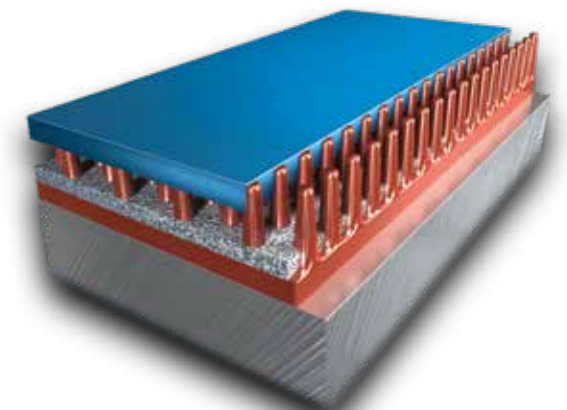

- Coating structure:**
1. Aluminium base material
 2. Barrier coat
 3. Eloxal pores
 4. Metal oxides
 5. Compression

Comprehensive selection. Unlimited design freedom.

Whether building façades or interiors: architecture can be designed with colour. For this, heroal has a diverse range of innovative coating technologies with which it can offer an extensive spectrum of shades and surfaces in durable and highly weather-resistant quality.

RAL, DB colours and co.

heroal products are available in over 500 colours from the RAL and DB colour range. Plus in many other shades. An impressive selection that opens up countless possibilities for individual colour design.

heroal Surface Design (SD)

This innovative coating technology lets you create high-quality wood, rust and concrete looks. A finish that offers greater design freedom as well as exceptional durability. The desired design is carefully burned onto the previously applied hwr powder coating. The designs form a firm connection with the underlying paint layer on all sides: this is how the combined heroal coating processes ensure a first-class surface quality.

Les Couleurs® Le Corbusier

Thanks to the exclusive partnership between heroal and Les Couleurs® Le Corbusier, you have access to an equally exclusive colour system: the 63 natural shades were deliberately chosen to harmonise with each other in any combination. The combination with Le Corbusier colours give the aluminium systems for windows, doors, curtain walls, roller shutters, sun protection, roller doors and patio roofs a particularly high-end look. heroal's great coating expertise ensure durable, colour-intensive and colour-fast surfaces.



"colour design diversity" brochure



heroal Surface Design (SD)



Set no limits to creativity.

Architecture can be a whole lot more than straight lines and right angles. Do you have ideas that you would like to bring to life with an expert partner? heroal processing services are industry-leading – and for good reason. With our state-of-the-art systems, we can carry out even the most complex profile bending work: round, segmental and basket bends or circular elements as well as precisely fitting, reproducible folds and structural attachments.

The basis of a high-quality formed element is the perfect curve: heroal manufactures and uses its own bending rollers and tools to achieve and guarantee an optimum bending result for the profile cross-sections. And all to the high standard you have come to expect from heroal. heroal formed elements are completely welded. This makes joints virtually invisible. After the bending process, the desired colour design is applied with a high-quality heroal hwr powder coating in our own coating systems. Good ideas, perfectly realised: heroal processing services give your creativity free rein.

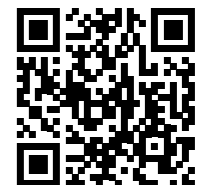

Scan and view film

Building-specific special solutions for architectural freedom.

heroal's design-adapted building solutions offer a diversity of shapes for particularly sophisticated structures. The design level is modified according to the architectural requirements of the planner or architect. Solutions here include, for example, aluminium half-shells or cover profiles. The system properties of the standard series remain 100% unchanged when implemented in building solutions, as the functional level – outlined here in red – remains unchanged.

Feel free to contact us if you require further information or have specific construction projects. You can find references with special solutions starting on page 148.

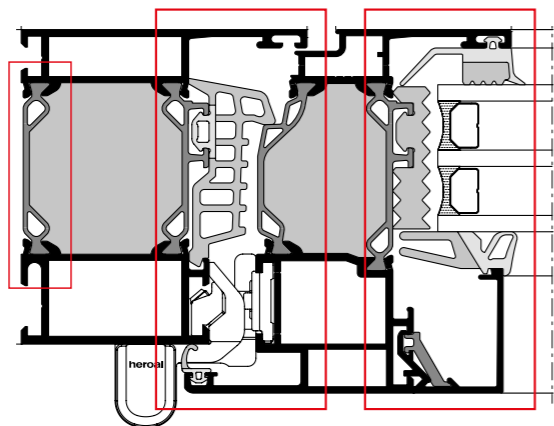
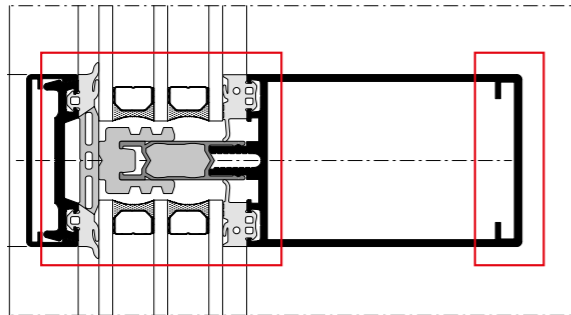

Special solutions require special tests

Separate testing is required for requirements that go beyond existing system tests, e.g. if the tested element sizes are exceeded, in case of installation in an exposed position or for building solutions that deviate from the standard systems. heroal takes charge of this project-specific assessment and, in the process, can draw on many years of experience with many tests. In many cases, this makes it possible to receive special approvals without having to conduct a special external test. Whenever a special test proves necessary, heroal takes over the complete processing of the project-specific verification. The tests can be carried out in our own test centre with the ift Rosenheim-certified test stand or with accredited external testing institutes. This way, your building solution can be implemented quickly and easily.

The following tests can be carried out in our test centre:

- » differential climate / climate
- » air permeability
- » tightness against driving rain
- » resistance level to wind load
- » mechanical durability
- » operating forces
- » shock resistance

For all other areas, we work together with renowned and accredited testing institutes:

- » heat transfer coefficient
- » fire resistance
- » soundproofing
- » burglary resistance
- » approval capability
- » load-bearing capacity of safety equipment

Window systems for optimum heat insulation.

heroal window systems impress with their unlimited variety of colours and designs and slimline look with top performance in terms of heat insulation, soundproofing and security. A wide range of design variants, modular heat insulation and combination options with the heroal system portfolio, e.g. with sun protection and ventilation systems, offer architects and planners functional versatility.

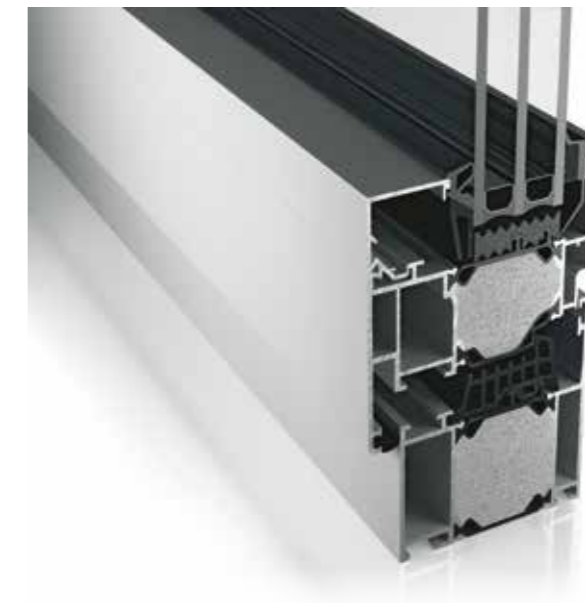

heroal window systems:

- + low design depths and slim view widths
- + burglary resistance up to RC 4 (in combination with heroal roller shutters)
- + high heat insulation up to passive house certification
- + round, segmental and basket bends as well as circular elements
- + highly weather-resistant heroal hwr powder coating
- + comprehensive version and design options
- + automated window systems with electric window drive possible

System dimensions

Description		heroal W 77	heroal W 77 HI	heroal W 77 UD	heroal W 77 PH	heroal W 77 i	heroal W 72	heroal W 72 HI	heroal W 72 UD	heroal W 72 i		heroal W 72 RL / CL	heroal W 72 CW		heroal W 65
		Exterior glazing		Interior glazing		Steel effect		Curtain wall look							
Profile installation depth [mm]	Frame profiles	77	77	77	77	77	72	72	72	72		82	106	72	65
	Crossbar profiles	77	77	77	77	77	72	72	72	76.5	79	84	76.5-84		65
	Sash profiles	89	89	89	89	84	84	84	84	72		81	102-106	72	77
Profile view width [mm]	Frame profiles	50-250	50-250	50-60	145	70-140	50-250	50-250	60-85	70-120		60-154	38/50	28	50-154
	Crossbar profiles	74-254	74-254	84-104	164	94-194	74-254	74-254	84-124	114-244		74-94	50		74-254
	Sash profiles	33-67	33-67	33-67	43	34	33-67	33-67	33-67	concealed		33-43	concealed		33-95
Min. view width frame/sash profile [mm]		90	90	90	180	81	90	90	100	77	81	100	77	97	90
Sash profile variants	SBN ¹⁾	•	•	•	•	•	•	•	•	•	•	•	•	•	•
	KBN ²⁾	•	•	•	•	•	•	•	•	•	•	•	•	•	•
Max. glass/infill panel thickness [mm]	Frame profiles	58	54	54	54	54	54	54	54	52		54	44		54
	Sash profiles	70	66	66	66	64	66	62	66	48		58	64		64
Glass inset [mm]	Frame profiles	18	18	-	18	11	19	18	19	11		19	11		-
	Sash profiles	18	18	-	18	11	19	18	19	11		19	11/19		-
Max. casement weight [kg]		300	300	300	300	-	300	300	300	300		300	300		300
Max. sash height [mm]		2,800	2,800	2,400	2,800	-	2,800	2,800	2,400	2,400		2,800	2,800 ³⁾		2,800
Max. sash width [mm]		1,600	1,600	1,200	1,600	-	1,600	1,600	1,200	1,200		1,600	1,600 ³⁾		1,600

System features

Description	heroal W 77	heroal W 77 HI	heroal W 77 UD	heroal W 77 PH	heroal W 77 i	heroal W 72	heroal W 72 HI	heroal W 72 UD	heroal W 72 i		heroal W 72 RL / CL	heroal W 72 CW		heroal W 65
	Exterior glazing		Interior glazing		Steel effect		Curtain wall look							
Heat insulation [U _i in W/m²K]	≥ 0.76	≥ 0.74	≥ 1.30	≥ 0.78	≥ 0.77	≥ 0.85	≥ 0.79	≥ 1.6	≥ 1.5	≥ 1.7	≥ 1.3	≥ 1.5	≥ 1.3	≥ 2.5
Heat insulation [U _i in W/m²K] / Profile view width [mm]	1.1/120	0.95/120	1.2/88	0.78/180	1.0/101	1.3/120	1.2/120	1.8/88	1.5/91	1.7/91	1.3/120	1.5/100	1.3/120	2.5/120
Heat insulation [U _w in W/m²K]	≥ 0.77	≥ 0.72	≥ 0.73	≥ 0.67	≥ 0.72	≥ 0.84	≥ 0.80	≥ 0.82	≥ 0.83	≥ 0.87	≥ 0.84	≥ 0.86	≥ 0.84	≥ 1.3
Air permeability	4	4	4	4	4	4	4	4	4	4	4	4	4	4
Tightness against driving rain	9A	9A	9A	9A	9A	9A	9A	9A	9A	9A	9A	9A	9A	9A
Wind load resistance	C5/B5	C5/B5	C2/B2	C5/B5	C5/B2	C5/B5	C5/B5	C2/B2	C5/B5	C5/B5	C5/B5	C5/B5	C5/B5	C5/B5
Soundproofing class (SSK)	1-5	1-5	-	1-5	1-5	1-5	1-5	-	1-5	1-5	-	-	-	1-5
Burglary resistance up to	RC 3/RC 4 ⁴⁾	RC 3/RC 4 ⁴⁾	RC 2	RC 3/RC 4 ⁴⁾	RC 2	RC 3/RC 4 ⁴⁾	RC 3/RC 4 ⁴⁾	RC 2	RC 2	RC 2	RC 3	-	-	RC 3
Operating forces	1	1	1	1	1	1	1	1	1	1	1	1	1	1
Shock resistance	5	5	-	5	5	5	5	-	5	5	5	-	-	5
Mechanical durability	4	4	4	4	4	4	4	4	4	4	4	-	-	4
Load-bearing capacity of safety equipment	ful-filled	ful-filled	ful-filled	ful-filled	ful-filled	ful-filled	ful-filled	ful-filled	ful-filled	fulfilled	ful-filled	fulfilled	fulfilled	ful-filled
Continuous function	3	3	-	3	3	3	3	-	3	3	2	-	-	2
NSHEV and SHEV approval	-	-	-	-	-	•	-	-	-	-	-	-	-	-

Types of opening and versions

Description	heroal W 77	heroal W 77 HI	heroal W 77 UD	heroal W 77 PH	heroal W 77 i	heroal W 72	heroal W 72 HI	heroal W 72 UD	heroal W 72 i		heroal W 72 RL / CL	heroal W 72 CW		heroal W 65
	Exterior glazing		Interior glazing		Steel effect		Curtain wall look							
Turn [D], tilt and turn [DK], tilt before turn elements [TBT]	•	•	•	•	•	•	•	•	•	•	•	•	•	•
Forend elements	•	•	•	-	•	•	•	•	•	•	•	•	•	•
Parallel sliding/tilting elements [PSK]	•	•	-	-	-	•	•	-	-	-	-	-	-	•
Skylight elements [OL]	-	-	-	-	-	•	•	-	•	•	•	•	•	•
Swinging/turning elements [PW]	-	-	-	-	-	•	•	-	-	-	-	-	-	-
Outward opening elements [o.o.]	-	-	-	-	-	•	•	-	-	-	-	-	-	•
Fixed glazing	interior	•	•	•	•	•	•	•	•	•	•	•	•	•
	exterior	-	-	-	-	-	-	-	•	•	-	-	-	•
Accessibility DIN 18040	-	-	•	-	-	-	-	•	-	-	-	-	-	-
heroal DS drainage system	-	-	•	-	-	-	-	•	-	-	-	-	-	-
Curtain wall integration	•	•	•	•	•	•	•	•	•	•	•	•	•	•
Min. view width [mm]	86	86	86	86	77	86	86	100	75	79	-	-	-	86
System-compatible heroal door system	heroal D 72	heroal D 92 UD	-	heroal D 92 UD	heroal D 72	heroal D 72	heroal D 72	heroal D 72	heroal D 72		heroal D 72 RL/CL	heroal D 72		heroal D 65
Fitting variants	heroal WF 100	RC 3	RC 3	RC 2	•	•	RC 3	RC 3	RC 2	RC 2	RC 3	•	•	RC 2
	heroal WF 100 i	RC 3	RC 3	RC 2	•	•	•	•	•	RC 2	RC 3	•	•	RC 2
	heroal WF 200	•	•	•	•	•	•	•	•	•	•	• ³⁾	•	•
	heroal WF 300	•	•	•	•	•	•	•	•	•	•	• ³⁾	•	•
Integ. motorisation (heroal WF Drive)	•	•	•	•	•	•	•	•	•	•	-	-	•	
Ventilation flap (heroal W 72 VF)	-	-	-	-	-	•	•	•	-	-	-	-	-	-
Window rebate fan	•	-	-	-	-	•	-	-	-	-	-	-	-	-
Fall protection	•	•	•	•	•	•	•	•	•	•	-	•	•	•
Insect screen integration ⁵⁾	•	•	•	•	•	•	•	•	•	•	•	•	•	•

Design

Description	heroal W 77	heroal W 77 HI	heroal W 77 UD	heroal W 77 PH	heroal W 77 i	heroal W 72	heroal W 72 HI	heroal W 72 UD	heroal W 72 i		heroal W 72 RL / CL	heroal W 72 CW		heroal W 65
	Exterior glazing		Interior glazing		Steel effect		Curtain wall look							
heroal hwr powder coating	•	•	•	•	•	•	•	•	•	•	•	•	•	•
Eloxal coating	•	•	•	•	•	•	•	•	•	•	•	•	•	•
heroal SD	•	•	•	•	•	•	•	•	•	•	•	•	•	•
Les Couleurs® Le Corbusier	•	•	•	•	•	•	•	•	•	•	•	•	•	•
Bending technology (formed elements)	-	-	-	-	-	•	-	•	•	•	•	•	•	•
Edging and laser machining	•	•	•	•	•	•	•	•	•	•	•	•	•	-

¹⁾ Push rod fitting groove

²⁾ Plastic fitting groove

³⁾ With use of heroal W 72 sash profiles

⁴⁾ In conjunction with matching heroal roller shutter system

⁵⁾ Front-mounted installation only

heroal W 77 The window system for today and tomorrow

Thanks to an intelligent combination of geometry and material, the heroal W 77 window system achieves a U_f value of $0.95 \text{ W/m}^2\text{K}$ (view width 120 mm) at passive house level with a design depth of just 77 mm. This development has made it possible to harmonise the thermally separated aluminium window not only with the requirements of today, but also with those of the “nearly zero-energy buildings” of tomorrow.

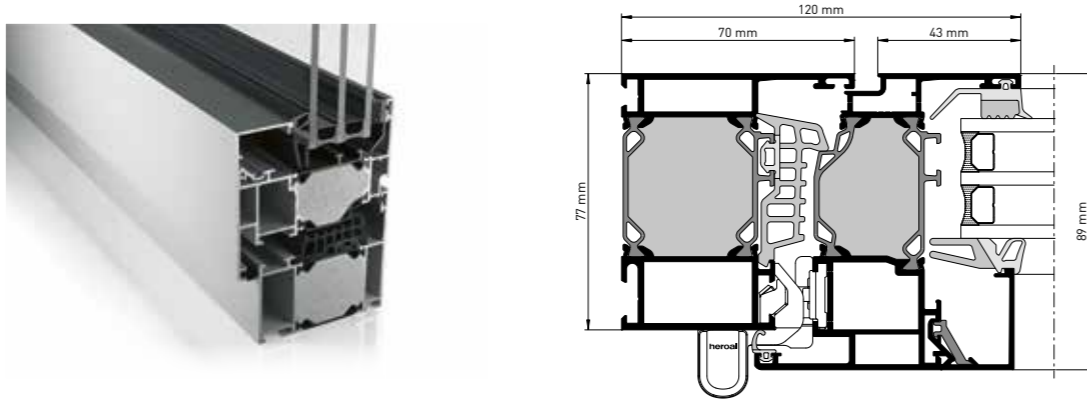

Design and insulation variants:

- » heroal W 77 HI (High Insulation) - with high heat insulation
- » heroal W 77 UD (Universal Design) - accessible

heroal W 77 PH The passive house-certified window system.

With a design depth of just 77 mm and a view width of 180 mm, the heroal W 77 PH window system meets the high requirements of Dr Feist’s Passive House Institute. It reaches a passive house-compatible U_f value of $0.8 \text{ W/m}^2\text{K}$ with a view width of just 120 mm.

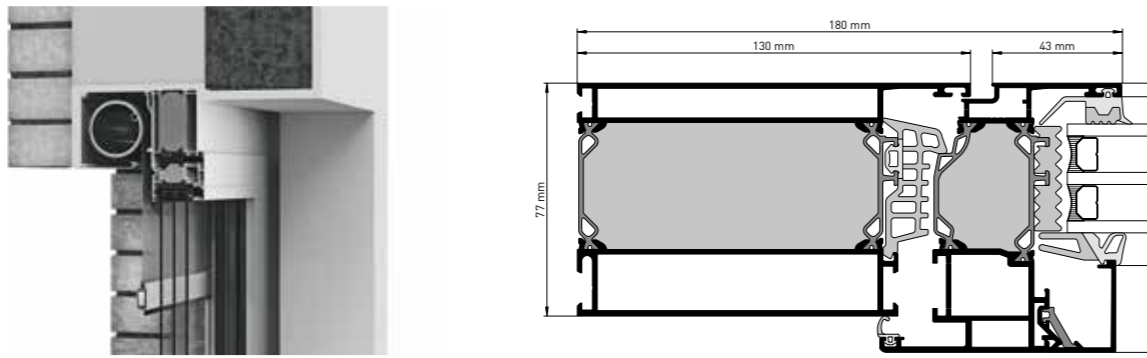

heroal W 77 i Block window system with internal glazing.

The heroal W 77 i block window system with internal glazing features slim view widths, large glass surfaces and maximum transparency. The outer appearance of the window with no visible sashes, which ideally emphasises the narrow view widths of the system, and heat insulation values of $U_f = 1.0 \text{ W/m}^2\text{K}$ (in the standard cross-section) meet the highest architectural and energy requirements. The window system can also be integrated into the curtain wall as a floating window.

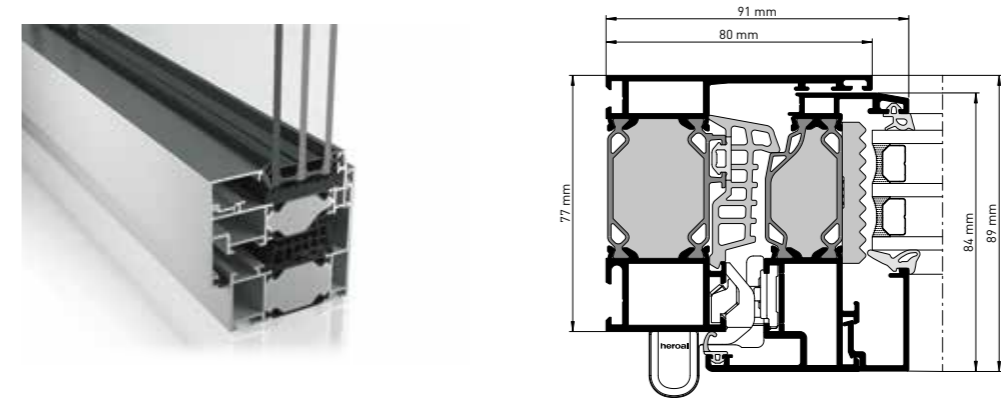

Design and insulation variants:

- » heroal W 77 i UD (Integrated Universal Design) - accessible

heroal W 72 The innovative system solution for every range of application.

heroal W 72 is the innovative and sustainable aluminium window system solution from heroal. The system offers top quality with maximum energy and cost efficiency – both its production and throughout its entire service life. Thanks to its numerous innovative and construction-related advantages, it impresses in every range of application.

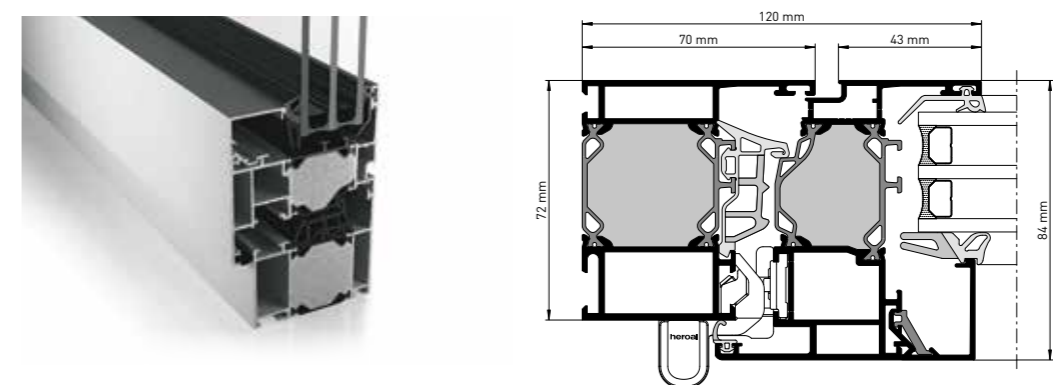

Design and insulation variants:

- » heroal W 72 HI (High Insulation)
- » heroal W 72 UD (Universal Design) - accessible

heroal W 72 i Block window system with internal glazing.

The heroal W 72 i window system with interior glazing unites architectural design and slim view widths. heroal W 72 i offers maximum transparency, heat insulation and an elegant design with no visible casements. The block window system can be used in a variety of applications, including as a curtain wall insert element (floating window). Its combination with concealed fittings gives the system an elegant design.

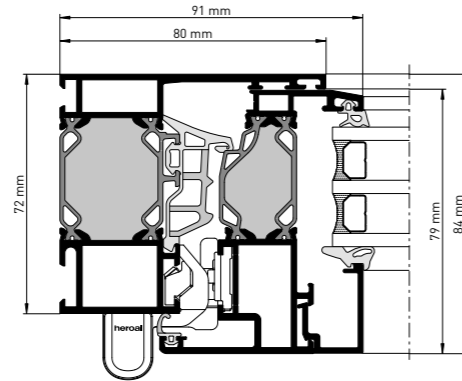
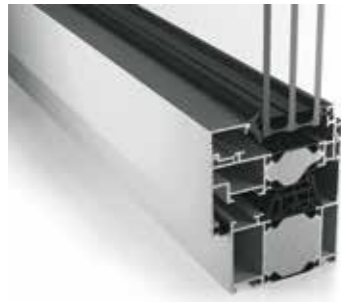

Design and insulation variants:

- » heroal W 72 i (Integrated) - exterior glazing
- » heroal W 72 i UD (Integrated Universal Design) - accessible

heroal W 72 CL Window system with bevelled outer contour.

The heroal W 72 CL window system in a bevelled design (Classicline contour) with balanced proportions is perfect for renovating or refurbishing old buildings. The system combines an offset contour with tried-and-tested heroal system components. It is therefore the ideal solution for renovating old and listed buildings in residential and commercial construction.

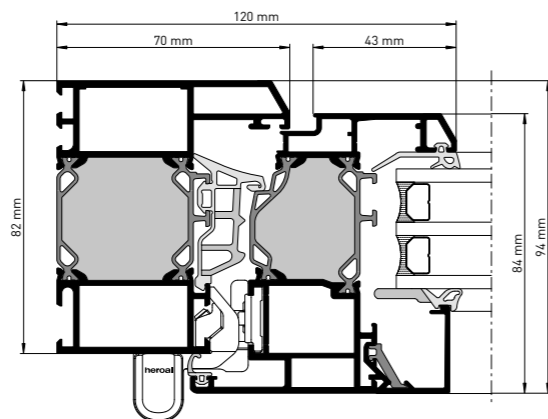
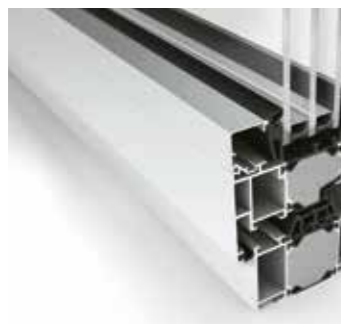

Design and insulation variants:

- » heroal W 72 RL (Roundline) - rounded outer contour

heroal W 72 CW Window system with steel effect.

The heroal W 72 CW window system offers planners individual, property-specific design variants for window elements at storey height. This allows for the creation of large openings in a classic transom-mullion look. A variety of profile variants make the heroal W 72 CW aluminium compound system an attractive alternative to steel curtain walls.

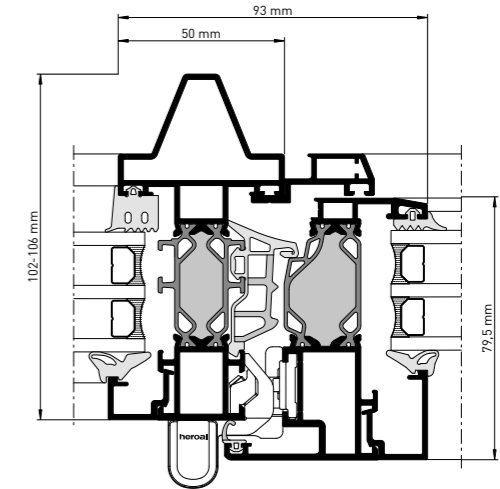

Design and insulation variants:

- » heroal W 72 CW (Curtain Wall) - curtain wall look

heroal W 65 Economical system solution for windows.

The heroal W 65 system stands for particularly economical window solutions. It simultaneously meets the highest quality requirements: with 3-chamber profiles and tried-and-tested fittings, the system boasts high-quality components and also impresses with its soundproofing and burglary resistance.

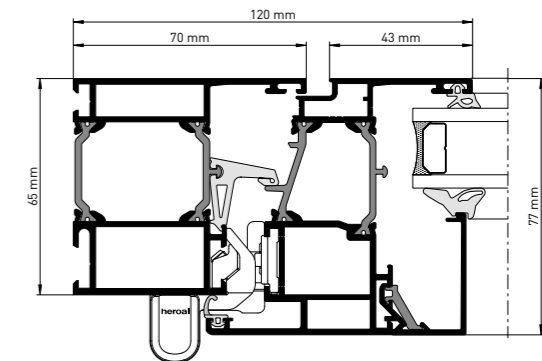
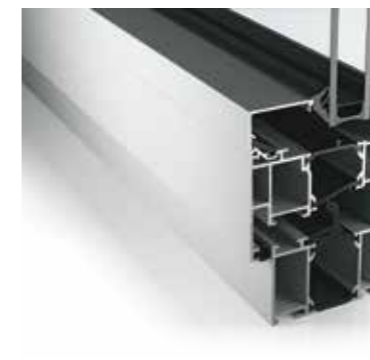

Complementary solutions. Functional and versatile.



heroal WF (window fitting system)

heroal fitting systems for windows grant the greatest possible freedom of design and contemporary handle designs. They are distinguished by their durability, security and functionality. Besides its RC 2 and RC 3 certification, heroal WF also impresses with its standard basic security. Whether surface-mounted (WF 100, WF 200, WF 300) or concealed (WF 100 i), the right fitting can be found for any architecture.



Fall protection

heroal systems are used by a large number of manufacturers to test fall protection safeguards (e.g. glass balustrades or French balconies).



heroal WF Drive (integrated drive system)

The electric window drive heroal WF Drive offers automated locking, unlocking and tilting of all heroal window systems. Thanks to its installation on the window frame, no cable transition is required. This means that the drive is completely invisible when the window is closed. If the window is pushed closed in turned position, the integrated auto-lock function also locks it automatically. The heroal WF Drive can be controlled both by buttons and via an app. It can also be easily integrated in standard smart home systems.



heroal DS for window systems (drainage system)

The heroal DS drainage system for window systems ensures the backflow-free drainage of surface water, thereby acting as a reliable safeguard against indoor moisture damage. Thanks to having a threshold at the same level, the heroal DS drainage system allows the free passage of large window elements. Sealing levels around the circumference of the element and casement frame guarantee optimum tightness.



heroal W 72 VF (slimline ventilation flap)

The heroal W 72 VF ventilation flap satisfies the desire for a pleasant and healthy indoor climate. As a user-independent, motorised ventilation flap, it supports the implementation of controlled natural ventilation concepts day and night. Narrow, storey-high opening elements are integrated discreetly into the curtain wall. heroal W 72 VF is compatible with the heroal C 50, heroal W 72, heroal D 72 and heroal S 77 SL systems.



heroal IS (insect screen system for windows and doors)

The heroal KIS insect screen is easy to install and can also be retrofitted in front of almost all windows and doors. The stable and smooth-running heroal IS swivel frame is especially practical for heavily used doors and windows. heroal IS tenter frames are suitable for windows and doors that are tilted or fully opened for ventilation – even if roller shutters, folding shutters, sun protection or burglar grilles need to be taken into account during installation.



heroal W 72 and W 77 window rebate vent

The heroal window rebate vent for the heroal W 72 and heroal W 77 window systems ensures user-independent moisture protection according to DIN 1946-6. This prevents mould from forming in the room interior and guarantees the supply of fresh air for fans, for example. It is almost entirely concealed in the internal seal of the window and thus remains invisible from the inside and the outside when the window is closed. Air flows automatically due to the pressure differential inside the building.



heroal sun protection and heroal roller shutters

heroal sun protection and roller shutter systems can be optionally combined with heroal window systems. For a perfect colour match, the extruded aluminium components of the sun protection or roller shutter system can also be coated with the heroal hwr powder coating. This gives the entire building shell a uniform appearance.

Door systems for the highest demands.

heroal offers door systems for a wide range of applications: commercial building doors, front doors and fire protection doors, including matching thresholds, door casements and fittings. heroal systems deliver top performance in terms of energy efficiency, tightness, soundproofing and security and offer a particularly high degree of functionality and stability. Thanks to the customised surface finishing and the heroal profile bending and folding service, there are no limits to the possible designs. And our exclusive partnership with Les Couleurs® Le Corbusier resulted in the creation of the heroal Les Couleurs® Le Corbusier front door with door infill panel, which impresses with its exclusive, harmonious combinations of the Le Corbusier colours.



heroal door systems:

- + wide range of version and design options
- + top performance in terms of heat insulation, soundproofing and burglary resistance (RC 3)
- + highly weather-resistant heroal hwr powder coating
- + locks and door hinges for all door situations
- + suitable for emergency exit and escape routes and heavy-duty areas, and tested and approved in accordance with DIN 179 / DIN 1125

System dimensions

Description		heroal D 72	heroal D 72 RL	heroal D 72 CL	heroal D 65	heroal D 92 UD
Profile installation depth [mm]	Frame profiles	72	72-82	82	65	92
	Crossbar profiles	72	72-82		65	92
	Sash profiles	59-82	59-82		61-65	78-92
Profile view width [mm]	Frame profiles	60-250	60-154		60-250	85-120
	Crossbar profiles	70-254	70-94		74-254	94-120
	Sash profiles	56-124	56-100	56-85	56-124	56-85
Min. view width frame/sash profile [mm]		145	145		145	177
Max. glass/infill panel thickness [mm]	Frame profiles	54	54		46	70
	Sash profiles	72	72		56	92
Glass inset [mm]	Frame profiles	19	19		19	19
	Sash profiles	18	18		18	19
Max. casement weight [kg]		180	180		180	180
Max. sash height [mm]		2,500	2,500		2,500	2,500
Max. sash width [mm]		1,400	1,400		1,400	1,400

System features

Description	heroal D 72	heroal D 72 RL	heroal D 72 CL	heroal D 65	heroal D 92 UD
Heat insulation [U _i in W/m²K]	≥ 0.96	≥ 0.97	≥ 0.97	≥ 3.3	≥ 1.1
Heat insulation [U _i in W/m²K] Profile view width [mm]	1.7 145	1.7 145	1.7 145	3.2 145	1.3 177
Heat insulation [U _o in W/m²K]	≥ 1.0	≥ 1.0	≥ 1.0	≥ 1.6	≥ 0.70
Air permeability	4	4	4	4	4
Tightness against driving rain	E900	7A	7A	5A	9A
Wind load resistance	C4	C4	C4	C3	C5
Soundproofing class [SSK]	1-3	1-3	1-3	1-3	1-3
burglary resistance	RC 3	RC 3	RC 3	RC 3	RC 3
Operating forces	2	2	2	2	2
Shock resistance	4	4	4	4	-
Mechanical durability	3	3	3	3	3
Load-bearing capacity of safety equipment	fulfilled	fulfilled	fulfilled	fulfilled	fulfilled
Continuous function	8	6	6	6/8	6
Differential climate test d/e	2	-	-	-	2

Types of opening and versions

Description		heroal D 72	heroal D 72 RL	heroal D 72 CL	heroal D 65	heroal D 92 UD	
Swing doors	inward opening	•	•	•	•	•	
	outward opening	•	•	-	•	-	
Sash-concealing panel	inward opening	one-sided	•	•	•	•	
		both sides	•	•	•	-	•
	outward opening	one-sided	•	-	-	-	-
		both sides	•	-	-	-	-
Automatic doors		•	-	-	•	-	
Anti-finger-trap doors		•	-	-	•	-	
All-glass doors		-	-	-	-	-	
Push-pull doors		•	-	-	•	-	
Half-swing doors		•	-	-	•	-	
Double-acting swing doors		-	-	-	-	-	
French doors		•	•	•	•	-	
Folding doors		•	-	-	•	-	
Escape doors DIN 179 / 1125		•	-	-	•	-	
Escape doors CE. Proof / approval capacity DIN 179 / 1125		•	-	-	-	-	
Accessibility DIN 18040		•	•	•	•	•	
Zero barriers DIN 18040		•	•	•	-	-	
heroal DS drainage system		•	•	•	-	•	
Patented deformation-inhibiting compound in sash profiles		•	•	•	•	•	
Curtain wall integration Min. view width [mm]		• 126	• 126	• 126	• 126	-	
System-compatible heroal window system		W 72	W 72 RL	W 72 CL	W 65	-	
Fitting variants	U-forend	•	•	•	•	•	
	Flat forend	-	-	-	-	•	
Keyless entry (fingerprint)		•	•	•	•	•	
heroal front door panel		•	-	-	-	-	
heroal D 72 PF (Panel Fixed)		•	-	-	-	-	
heroal D 72 PF EM (Panel Fixed Easy Mount)		•	-	-	-	-	

Design

Description	heroal D 72	heroal D 72 RL	heroal D 72 CL	heroal D 65	heroal D 92 UD
heroal hwr powder coating	•	•	•	•	•
Eloxal coating	•	•	•	•	•
heroal SD	•	•	•	•	•
Les Couleurs® Le Corbusier	•	•	•	•	•
Bending technology (formed elements)	•	•	•	•	•
Edging and laser machining	•	•	•	•	•

heroal D 72 Building door system for heavily frequented entrance areas.

The heroal D 72 door system offers functional versatility with many types of opening and typical heroal performance features. The tested and certified heroal system can be used to implement all standard types of opening, including tested emergency exit and escape routes (in accordance with DIN EN 179 / 1125), automatic door systems, anti-finger-trap doors and burglar-resistant doors – also with emergency exit door function.

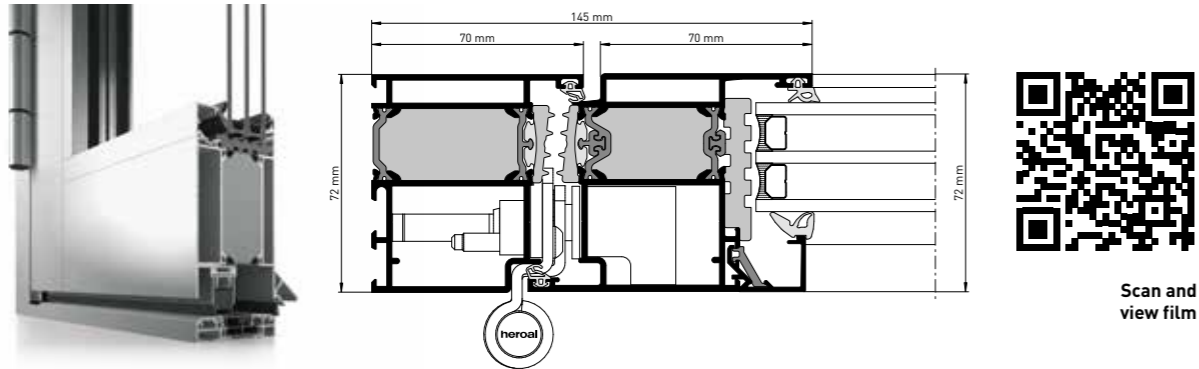

heroal D 72 CL Front door system with bevelled outer contour.

The heroal D 72 RL front door system with a harmonious Roundline contour or heroal CL with a Classicline contour offers functional versatility, a large number of design variants and excellent performance in terms of heat insulation and statics. The system is the ideal solution for heavily used entrance areas as well as for the renovation of old and listed buildings in residential and commercial construction. All standard types of opening can be implemented.

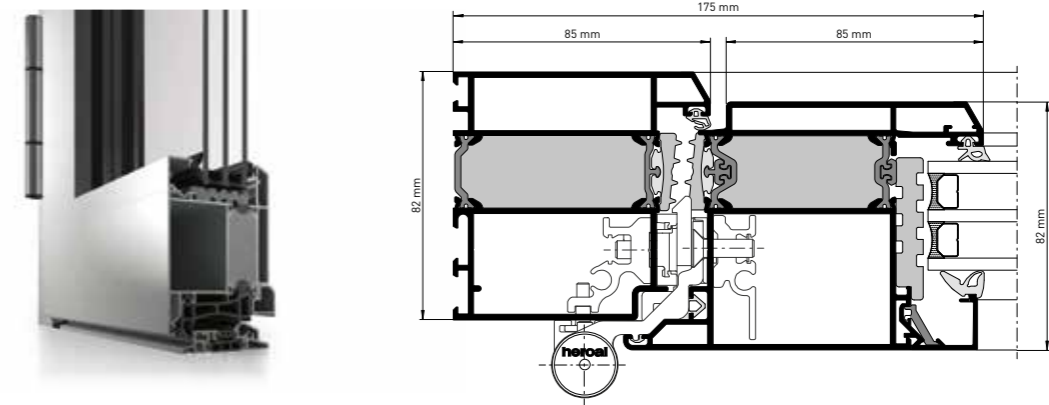

Design and insulation variants:

» heroal D 72 RL (Roundline) - rounded outer contour

heroal D 72 Front door system with unique quality and components.

The heroal D 72 front door system offers unique system variety. The best materials, maximum functionality, sophisticated design variants and maximum flexibility are the solid basis for individual products that are always exclusively custom-manufactured. heroal front door systems offer the greatest possible variety for a wide range of panel types and sophisticated system solutions for all installation situations in new or renovated buildings, whether exclusive and contemporary or timelessly elegant with a look that combines the classic and the modern.

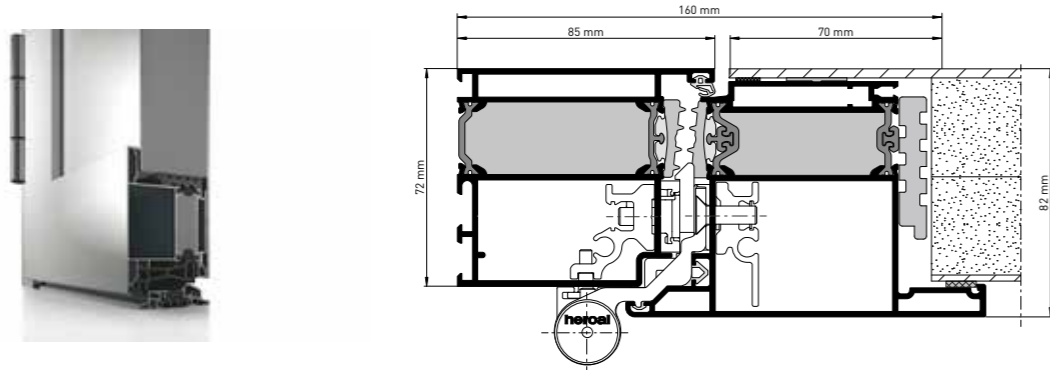

heroal D 65 Economical system solution.

The heroal D 65 door system offers economical solutions for doors that open inwards and outwards, including automatic door systems and escape doors. The 3-chamber profiles offer the best possible system reliability with the tried-and-tested system fittings in combination with the heroal system components. The heroal D 65 door system satisfies the highest demands in terms of ease of use and burglary resistance.

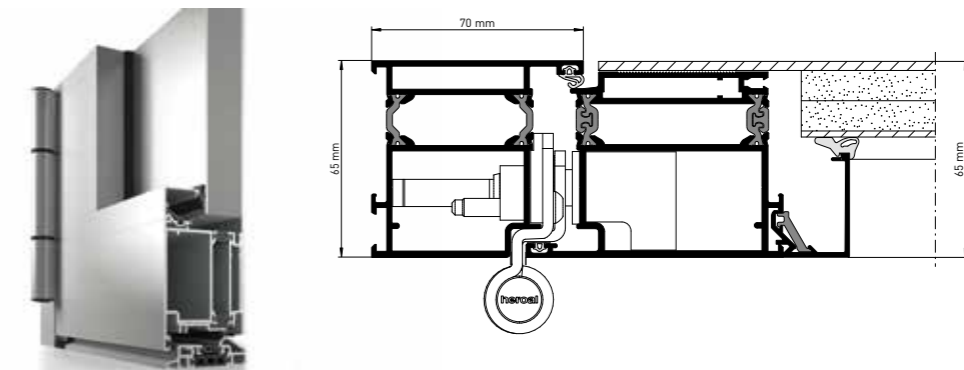

heroal D 92 UD The variable and high-performance front door system.

The heroal D 92 UD (Universal Design) front door system is characterised by an adaptive design and high heat insulation performance suitable for passive houses. With its modular construction, the system offers a wide range of design variants. The appearance and functional characteristics can be easily adapted to changing capabilities or new user requirements. This does not compromise the outstanding performance features or the functional operability of the system in any way.

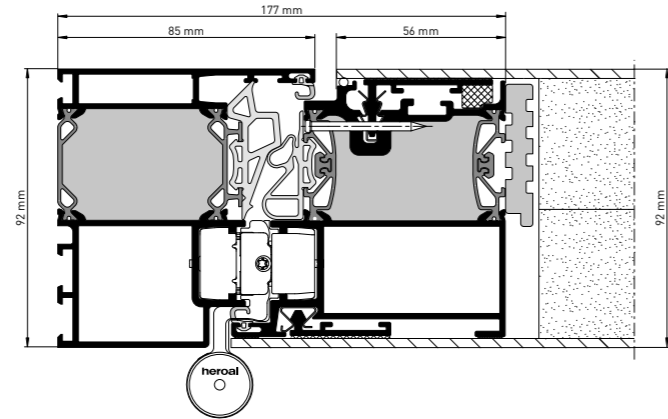

heroal Les Couleurs® Le Corbusier front door Le Corbusier exclusively from heroal.

The heroal Les Couleurs® Le Corbusier front door always combines the best materials, maximum functionality and perfect flexibility with the unique Le Corbusier colour spectrum. Each version of the door infill panel with resistance class RC 2 according to EN 1627 offers a high level of security. It is approved without restriction for burglar-resistant doors in the heroal D 72 profile system. Thanks to its contemporary design in combination with the exclusive Le Corbusier colour scheme, the Les Couleurs® Le Corbusier front door won the German Design Award 2020 in the category of "Excellent Product Design".

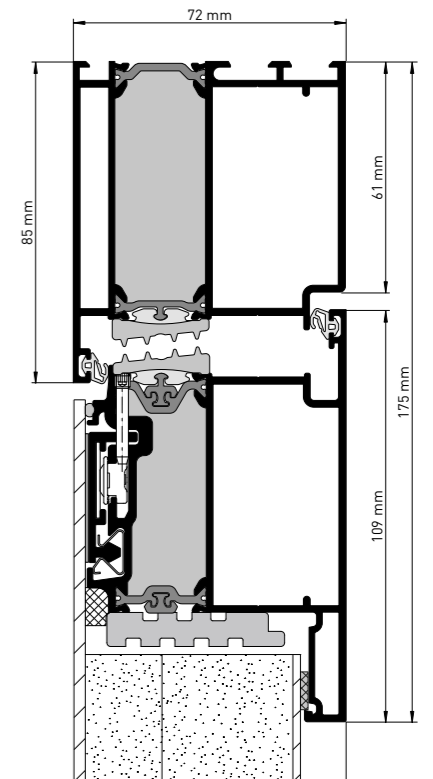

Complementary solutions. Functional and versatile.



heroal DF (door fitting system)

heroal DF fitting technology for commercial building and front door systems guarantees maximum flexibility and pursues the universal design approach, which can be individually tailored to the needs of users at any time and is additionally distinguished by intuitive handling and user-friendliness. A wide range of combinations of mechanical and electronic building components as well as standardised lock dimensions make a major contribution to this.



Keyless entry (fingerprint)

heroal door fittings are compatible with the latest technologies – including, for example, Bluetooth and keyless entry, which further increase the ease of use. Keyless entry not only permits doors to be opened via an app, but also the integration of fingerprint access solutions.



heroal front door panel

The heroal front door panel has a discreet, timeless look with an integrated and illuminated recessed handle. In each version, the door infill panel with resistance class RC 2 in accordance with EN 1627 offers a high level of security and is approved without restriction for burglar-resistant doors in the heroal D 72 profile system. It achieves a U_0 value in W/m^2K of 0.91 with a door size of 1,230 x 2,180 mm and an infill panel thickness of 60 mm. The heroal front door panel can be coated in all heroal colours and designs. The handle is available in three lengths with or without LED light strips.



heroal DS for door systems (drainage system)

Special measures must be taken to make thresholds in the area of door elements accessible in accordance with regulations while protecting against moisture damage indoors. One secure system solution is the use of the heroal DS drainage system for door systems, which drains away any surface water with no backflow.



heroal D 72 PF (Panel Fixed)

The heroal PF casement without glass strip ensures a particularly aesthetic, discreet design and looks like it was cast from a single mould from the inside. The reversible infill panel attachment makes it possible to attach the prefabricated infill panel through joints in the casement. The different options for heroal infill panel attachments allow the manufacture of maximum casement sizes. Extremely simple installation even on the construction site, design modification and replacement options, and time-saving fabrication are the advantages of this attachment.



Scan and view film



heroal D 72 PF EM (Panel Fixed Easy Mount)

The heroal D 72 PF EM sash profile is based on the heroal D 72 system logic and supports exceptionally fast and efficient door fabrication using the same tools. The profile geometry, including the fixed internal backstop without glass strip (PF = "Panel Fixed") is designed for a standardised door panel thickness of 48 mm. This and other design solutions ensure easier and more efficient fabrication and installation (EM = "Easy Mount"). heroal D 72 PF EM is thus the ideal solution for particularly economical fabrication with reduced equipment and design options.

Sliding and lifting-sliding systems for maximum transparency.

heroal aluminium sliding and lifting-sliding systems offer the perfect combination of transparency and heat insulation, even for large areas. Different types of opening and design variants give planners and architects the freedom to combine comfort and functionality. The tried-and-tested heroal technologies also ensure optimum results in terms of accessibility, air permeability, tightness against driving rain and burglary resistance. Versions as 90 degree corners for opening or fixed all-glass corners ensure a smooth transition between the inside and the outside.



heroal sliding and lifting-sliding systems:

- + wide range of version and design options
- + fixed glazing, 90 degree corners for opening or all-glass corners
- + highly weather-resistant heroal hwr powder coating
- + top performance in terms of heat insulation, soundproofing and burglary resistance
- + automated lifting-sliding systems with electric drive possible

System dimensions

Description		Lifting-sliding systems				sliding systems			
		heroal S 77		heroal S 77 SL		heroal S 65		heroal S 42	
		S 77	S 77 HI	S 77 SL	S 77 SL HI	S 65	S 65 HI	S 42	S 42 HF
Profile installation depth [mm]	Frame profiles	178 / 279		202		154		72 / 132 113	
	Crossbar profiles	72		72		-		38	
	Sash profiles	77		77		65		38 / 42	
Profile view width [mm]	Frame profiles	35 - 52		40 - 52		57		48 concealed	
	Crossbar profiles	74 - 104		74 - 104		62 - 87		68	
	Sash profiles	94	104	104		-		68 / 72	
	Central joint	114	124	104		62		35	
Glass inset [mm]	Frame profiles	-		18		-		-	
	Sash profiles	18		18		16		13	
Max. glass/infill panel thickness [mm]	Frame profiles	-		52		-		-	
	Sash profiles	52		52		47		24-28	
Max. casement weight [kg]		400		400		250		160	
Max. sash height [mm]		3,000		3,000		2,400		2,600	

System features

Description	Lifting-sliding systems				sliding systems			
	heroal S 77		heroal S 77 SL		heroal S 65		heroal S 42	
	S 77	S 77 HI	S 77 SL	S 77 SL HI	S 65	S 65 HI	S 42	S 42 HF
Heat insulation [U_f in W/m^2K] ¹⁾	2.2	2.1	2.1		≥ 2.4		-	-
Heat insulation [U_w in W/m^2K] ²⁾	≥ 1.0	≥ 1.0	≥ 0.86		≥ 1.1		≥ 1.3	≥ 1.2
Air permeability	4		4		4		4	4
Tightness against driving rain	9A		9A		7A		8A	8A
Wind load resistance	C3/B3		C3/B3		B2		C3/B4	C1/B2
Soundproofing class [SSK]	3		3		-		3	3
burglary resistance	RC 2		RC 2		RC 2		-	-
Operating forces	1		1		1		1	1
Protection against corrosion	5		5		-		-	-

¹⁾ U_f -value according to EN ISO 10077-2; average value of the frame combinations

²⁾ U_w -value according to EN ISO 12567-1; determined based on an element size of 3500 × 2180 mm

³⁾ Front-mounted sun protection possible

Versions

Description	Lifting-sliding systems				sliding systems			
	heroal S 77		heroal S 77 SL		heroal S 65		heroal S 42	
	S 77	S 77 HI	S 77 SL	S 77 SL HI	S 65	S 65 HI	S 42	S 42 HF
Number of runners	1-3		1		1-2		2-3 1	
Max. number of movable casements	6		2		2		6 2	
90° all-glass corner	-		•		-		- -	
90° corner for opening	-		•		-		• -	
Accessibility DIN 18040	•		•		•		• •	
heroal DS drainage system	•		•		•		- -	
heroal SF fitting system	•		•		•		• •	
Integrated motorisation (heroal SF Drive)	•		•		-		- -	
Curtain wall integration	•		•		•		• -	
Insect screen integration	•		•		•		• •	
Sun protection integration ³⁾	•		•		•		• •	

Design

Description	Lifting-sliding systems				sliding systems			
	heroal S 77		heroal S 77 SL		heroal S 65		heroal S 42	
	S 77	S 77 HI	S 77 SL	S 77 SL HI	S 65	S 65 HI	S 42	S 42 HF
heroal hwr powder coating	•	•	•	•	•	•	•	•
Eloxal coating	•	•	•	•	•	•	•	•
heroal SD	•	•	•	•	•	•	•	•
Les Couleurs® Le Corbusier	•	•	•	•	•	•	•	•
Bending technology (formed elements)	-	-	-	-	-	-	-	-
Edging and laser machining	-	-	-	-	-	-	-	-

heroal S 77 The versatile lifting-sliding system.

heroal S 77 is a modular profile system with a modern design that fulfils the highest structural requirements. It offers a choice of two view widths and an almost limitless selection of surfaces and is compatible with other heroal systems. heroal S 77 allow allows the implementation of multi-track design variants.

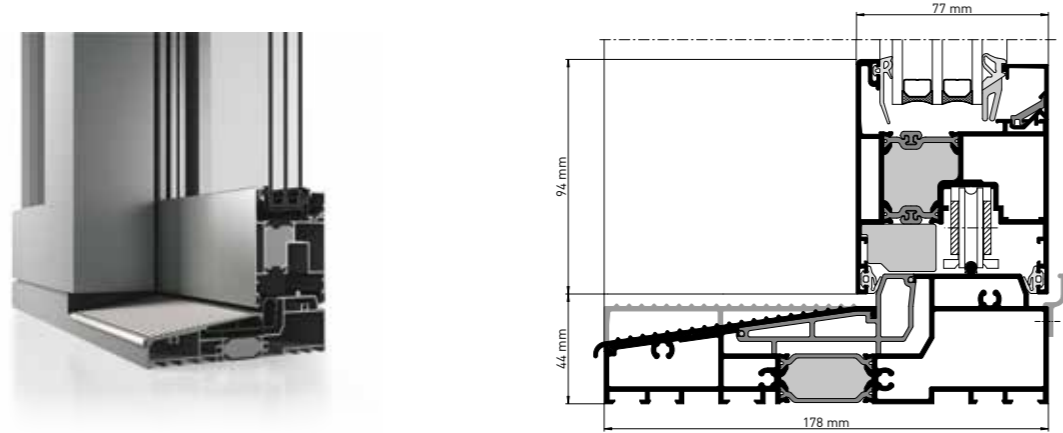

Design and insulation variants:

- » heroal S 77 HI (High Insulation) - with high heat insulation
- » heroal S 77 SC (Slim Compact) - without foam filling

heroal S 77 SL The design-oriented lifting-sliding system.

heroal S 77 SL can be used to create new dimensions on a large scale and guarantees maximum transparency with its unique and innovative frame construction. The new generation of heroal lifting-sliding doors combines a movable monorail casement with fixed frame glazing with minimal view widths.

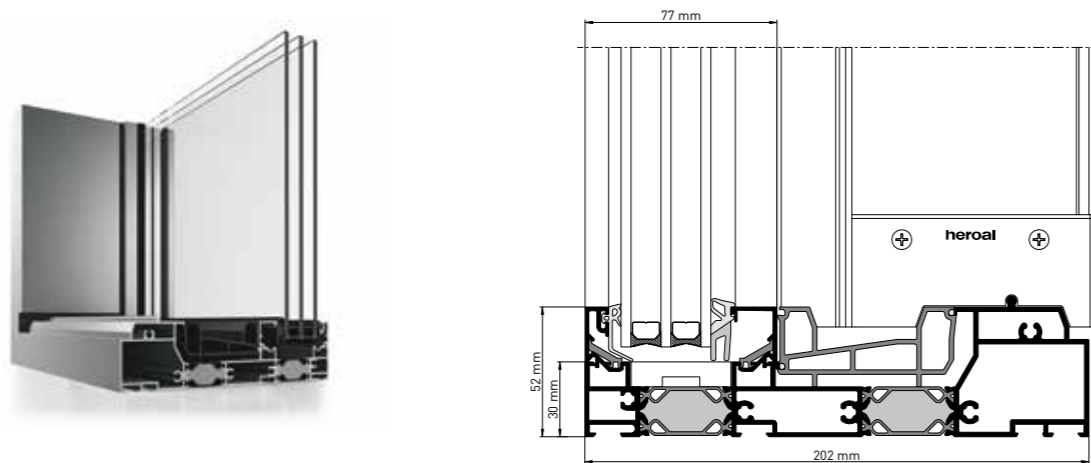

Design and insulation variants:

- » heroal S 77 SL SC (Slim Compact) - with or without foam filling
- » heroal S 77 SL HI (High Insulation) - with high heat insulation
- » heroal S 77 SL CC (Comfortable Climate) - with ultra-high heat insulation

heroal S 65 Sliding system for upscale residential and commercial construction.

In addition to the advantages in terms of fabrication and production and the resulting economical efficiency of this system, heroal S 65 also stands out due to its ease of use and contemporary design. Thanks to the slim central joint and narrow profile views, the system offers fascinating outlooks. Furthermore, the all-round frame reduces the complexity of the system, thus simplifying production even further.

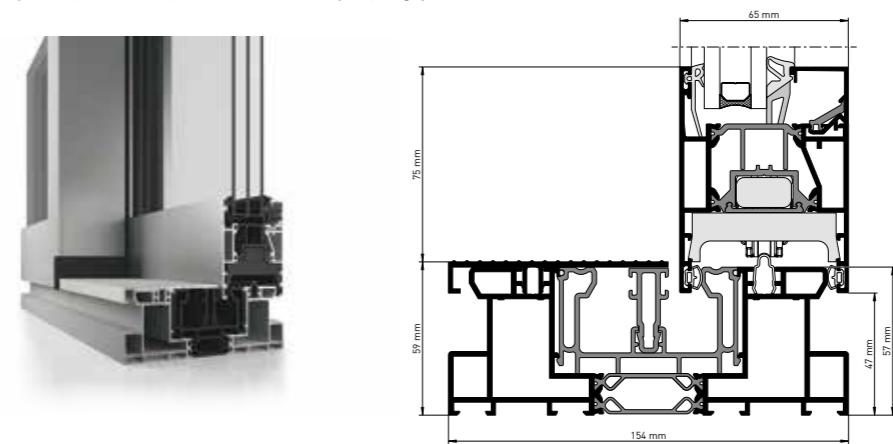

Design and insulation variants:

- » heroal S 65 HI (High Insulation) - with high heat insulation



Scan and view film



heroal S 42 Efficient and functional sliding system.

The heroal S 42 sliding system combines top quality and maximum energy and cost efficiency. A sleek look, accessibility and comfort are just a few of the performance features that describe the heroal S 42 sliding system. These guarantee versatile use as a double hung sash or sliding glass door in residential and industrial buildings.

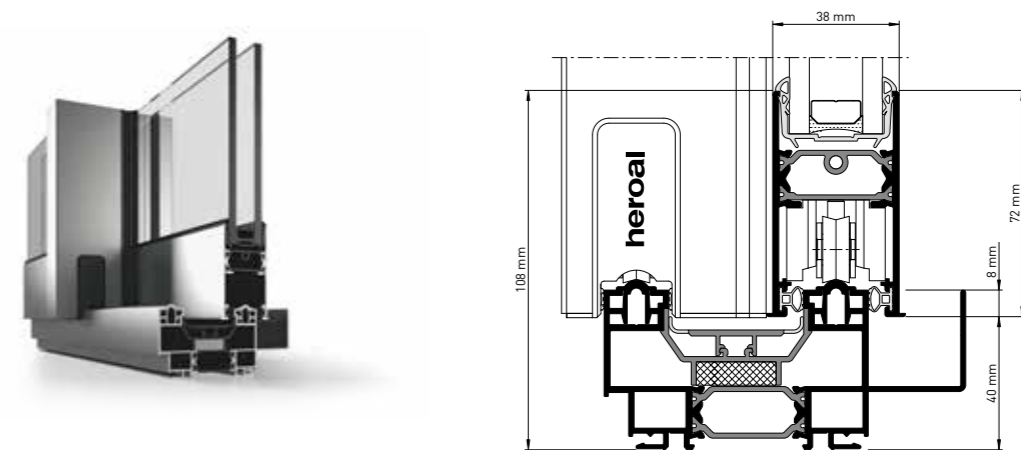

Design and insulation variants:

- » heroal S 42 HF (Hidden Frame) - for frameless transparency

Complementary solutions. Functional and versatile.

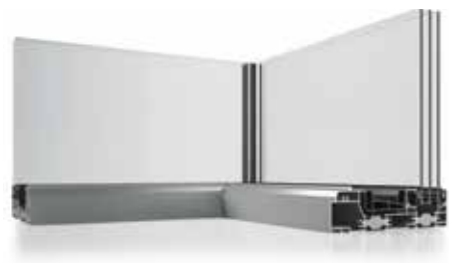

Version as 90° all-glass corner

Even in the joint area, there is no disturbing element frame to restrict the view. The 90° corner design with all-glass corner satisfies the increasing desire for transparency and flowing transitions between the inside and the outside.

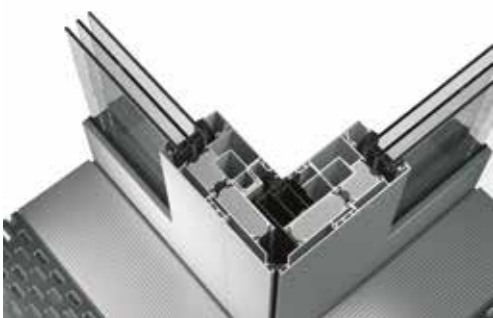

Version as 90° corner solution for opening

The version with a casement corner for opening will redefine any room. Corner areas can be opened completely without a support in the corner area blocking the way out. Even particularly large opening widths can be created without the need for a support.



heroal SF (fitting system)

The heroal SF system offers a high degree of flexibility and design freedom thanks to an extensive selection of handles in various versions ranging from half-moon to design handles. The handle variants can be combined on the interiors and exteriors of the elements.



heroal SF Drive (integrated drive system)

Fully integrated into the profiles, the drive system heroal SF Drive enables the extremely convenient and nearly noiseless operation of the heroal S 77 and heroal S 77 SL lifting-sliding door systems at the touch of a button – on request also via wireless remote control or smartphone app.



heroal DS for sliding and lifting-sliding systems (drainage system)

The heroal DS drainage system for sliding and lifting-sliding systems allows the free passage of large window elements without restrictions. Sealing levels around the circumference of the element and casement frame guarantee optimum tightness. The type of opening is independent of the system and is possible in combination with single, double and triple-track lifting-sliding door systems.



heroal IS pleated blind for sliding doors (insect screen)

The heroal pleated insect screen with vertical folding is ideal for use in any patio or balcony door – even for particularly large sliding doors.

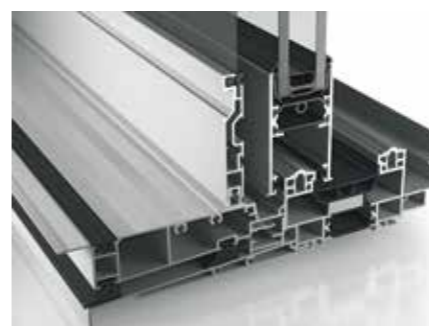

heroal IS sliding door (insect screen system)

Insect screen sliding systems from heroal are the ideal insect screen solution for particularly large sliding doors or patio and balcony door openings. Their low-noise operation, user and maintenance-friendly design, and variety of design options offer maximum comfort and full protection.

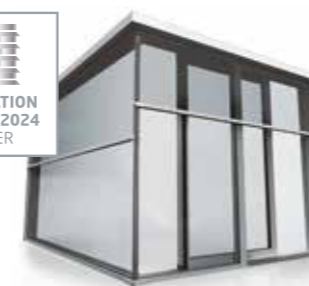

Scan and view film

heroal VS Z corner solution (sun protection system)

heroal sun protection systems can also be combined with the heroal sliding systems. For a perfect colour match, all aluminium components of the sun protection system can be coated with the heroal hwr powder coating. This gives the entire building shell a uniform appearance. The heroal VS Z corner solution provides aesthetic shading – even to all-glass corners.

Curtain wall systems for every requirement.

heroal curtain wall systems meet the increasing requirements for energy efficiency while affording maximum architectural freedom. Thanks to their variable and functionally reliable system components, heroal C 50 curtain wall systems offer fabricators, architects and planners solutions for almost any building project in private and commercial construction. The system variants heroal C 50 HI, heroal C 50 PH, heroal C 50 ID and heroal C 50 FP (featured in the chapter on fire and smoke protection systems) accommodate the increasing requirements for energy efficiency in the building shell, including passive house curtain walls, design variants such as industrial designs and fire protection. Thanks to its high level of system compatibility, the heroal curtain wall system can be combined with fully integrated sun protection solutions and a wide range of insert elements, such as block window systems, creating harmonious building shells.



heroal curtain wall systems:

- + wide range of insert elements and integration of sun protection possible
- + large spans with the heroal C 50 PS transom tensioning system
- + consistent view width of 50 mm even with wide glazing areas and high glass loads
- + uniform appearance and view width of curtain wall and fire protection curtain wall
- + various design variants
- + modular heat insulation up to passive house-certified

System dimensions

Description		heroal C 50	heroal C 50 HI	heroal C 50 PH	heroal C 50 ID	heroal C 50 GD
Profile installation depth [mm]	Mullion profiles	28 - 260	28 - 260	>115 - 260	95 - 185	28 - 260
	Transom profiles	6 - 215	6 - 215	>120 - 215	23 - 120	6 - 215
Profile view width [mm]		50	50	50	50	50
Max. glass/infill panel thickness [mm]		8 - 62	28 - 68	48	8 - 62	8 - 62
Max. glass/infill panel weight [kg]		800	up to 800	up to 800	up to 140	800

System features

Description		heroal C 50	heroal C 50 HI	heroal C 50 PH	heroal C 50 ID	heroal C 50 GD
Heat insulation [U_i in W/m^2K]		1.2 - 1.8	0.78 - 1.4	> 0.78	1.2 - 1.8	1.2 - 1.8
Air permeability [class]		AE	AE	AE	AE	AE
Tightness against driving rain	static	RE 1200	RE 1200	RE 1200	RE 1200	RE 1200
	dynamic	$P_{min} 250 PA$ $P_{max} 750 PA$	$P_{min} 250 PA$ $P_{max} 750 PA$	$P_{min} 250 PA$ $P_{max} 750 PA$	$P_{min} 250 PA$ $P_{max} 750 PA$	$P_{min} 250 PA$ $P_{max} 750 PA$
Wind load resistance	permissible load	2.0 kN/m ²	2.0 kN/m ²	2.0 kN/m ²	2.0 kN/m ²	2.0 kN/m ²
	increased load	3.0 kN/m ²	3.0 kN/m ²	3.0 kN/m ²	3.0 kN/m ²	3.0 kN/m ²
Soundproofing class [SSK]		up to 46 dB	up to 48 dB	NPD	up to 46 dB	up to 46 dB
Burglary resistance [class]		RC 3	RC 2	RC 2	RC 2	RC 3
Shock resistance [class]		I5/E5	I5/E5	I5/E5	I5/E5	I5/E5

Construction types

Description	heroal C 50	heroal C 50 HI	heroal C 50 PH	heroal C 50 ID	heroal C 50 GD
Transom-mullion / mullion-mullion / transom-transom	•	•	•	•	•
Non-ventilated curtain wall	•	•	•	•	•
Ventilated curtain wall	•	–	–	–	•
Unitised curtain wall/construction	•	•	–	–	•
Attachment curtain wall	•	•	–	–	•
Light roof construction	•	•	–	•	•
Cover shell range	•	•	•	•	•
heroal C 50 WG conservatory	•	•	–	–	•
heroal C 50 TC canopy construction	•	•	–	•	•

Insert elements

Description	heroal C 50	heroal C 50 HI	heroal C 50 PH	heroal C 50 ID	heroal C 50 GD
heroal window systems	•	•	•	•	•
heroal block window systems	•	•	•	•	•
heroal skylight elements	•	•	•	•	•
heroal W 72 VF ventilation flap	•	•	•	•	•
Floating window	•	•	–	•	•
heroal door systems	•	•	•	•	•
heroal sliding and lifting-sliding systems	•	•	–	•	•
heroal VS Z sun protection system	semi-integrated	•	•	–	•
	front-mounted	•	•	–	•
heroal C 50 PS transom tensioning system	•	•	•	•	•

Design

Description	heroal C 50	heroal C 50 HI	heroal C 50 PH	heroal C 50 ID	heroal C 50 GD
heroal hwr powder coating	•	•	•	•	•
Eloxal coating	•	•	•	•	•
heroal SD	•	•	•	•	•
Les Couleurs® Le Corbusier	•	•	•	•	•
Bending technology (formed elements)	•	•	•	•	•
Edging and laser machining	•	•	•	•	•
Cover shell range	•	•	•	•	•
Industrial design	–	•	–	•	–

heroal C 50 The system for a rich variety of curtain wall solutions.

The design of the thermally insulated heroal C 50 curtain wall system makes it ideal for use as a vertical or vertical-bending transom-mullion, transom-transom or mullion-mullion curtain wall. The curtain wall can also be used as a roof area, light roof pyramid or conservatory. A variety of cover and pressure profiles adds the finishing touch to the range of systems.

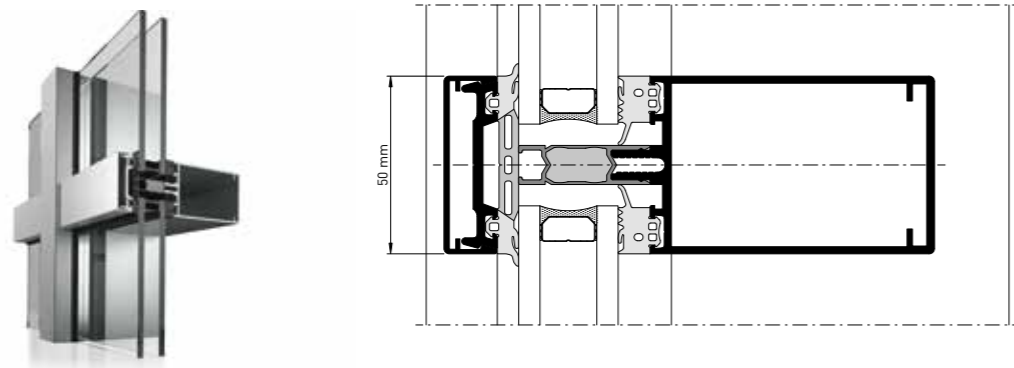

Design and insulation variants:

» heroal C 50 HI (High Insulation) - with high heat insulation

heroal C 50 PH The passive house-certified curtain wall system.

The heroal C 50 PH is the logical, systematic further development of the already highly thermally insulated heroal C 50 HI curtain wall system, which, in the transom-mullion version, can reach minimum U_f -values of $0.78 \text{ W} / \text{m}^2\text{K}$. With a suitable curtain wall panel and glazing, the system is passive house-certified.

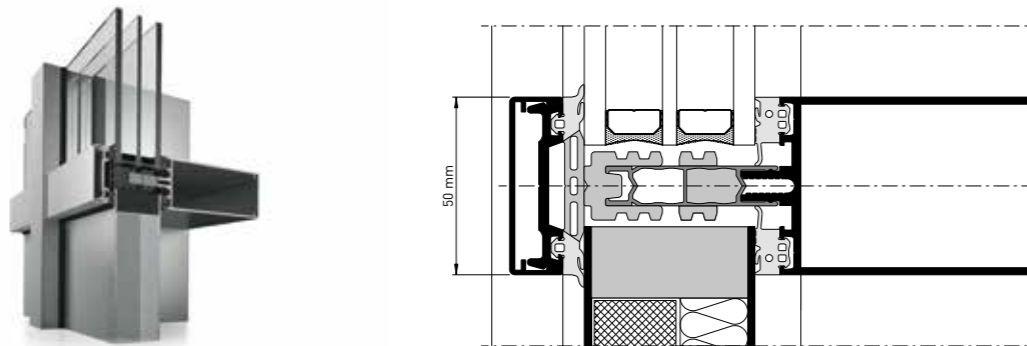

heroal C 50 ID The design-oriented curtain wall system with a steel effect.

The heroal C 50 ID curtain wall system stands for solution-oriented, creative curtain wall design for industrial applications. It allows planners, architects and fabricators to meet the highest requirements. The innovative concept for heat insulation with foam-filled insulators and an adapted insulator function as well as the continuous seal are standard features of the industrial design variant.

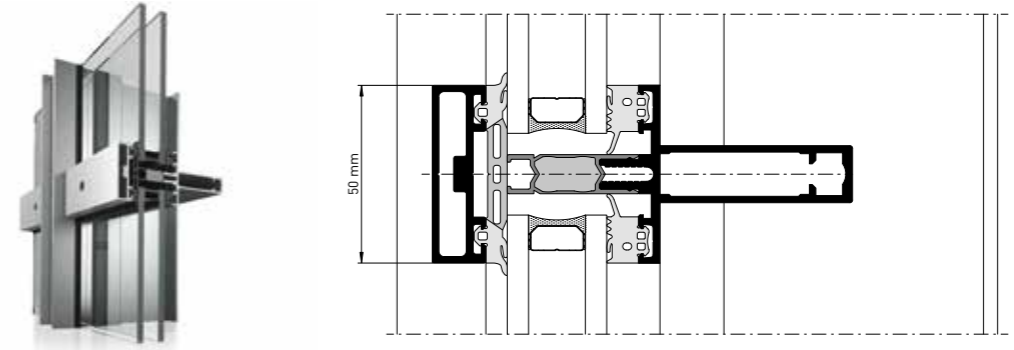

heroal C 50 GD Curtain wall concept for maximum transparency.

heroal C 50 GD (Glass Design) is a true highlight when it comes to curtain walls. The concept exploits the idea of reflection in two ways: it visually reduces the view width from the inside while reducing the design depth of the mullion from the outside. This effect is made possible by the use of a glass fin, which assumes the static role of the classic aluminium mullion.



Complementary solutions. Functional and versatile.



heroal C 50 PS (transom tensioning system)

The transom tensioning system from heroal is placed inside the profile. There it builds a pre-tension that counteracts the expected loads and stiffens the profile. This pre-tensioning of the profile can be individually adjusted to the expected useful and working loads. In addition, the glass weights can be further increased through the use of heavy-duty supports – allowing loads of up to 800 kg to be transferred in a 50 mm construction.



heroal C 50 TC (canopy system)

The versatile heroal C 50 curtain wall system can be used for the installation of the high-quality heroal C 50 TC canopy in up-scale residential and commercial buildings. With a maximum reach of 2,000 mm and an adjustable roof pitch, the canopy can be customised to suit individual requirements. The canopy is firmly connected to the curtain wall or structure. Loads of up to 6.5 kN are transferred per support. The slim profiles with a 60 x 50 mm rafter profile and a 50 x 50 mm support profile create slimline views.



heroal W 72 VF (ventilation flap)

The heroal W 72 VF ventilation flap satisfies the desire for a pleasant and healthy indoor climate. As a user-independent, motorised ventilation flap, it supports architects and planners in the implementation of controlled natural ventilation concepts day and night. Narrow, storey-high opening elements integrate discreetly into the curtain wall – simple, harmonious.

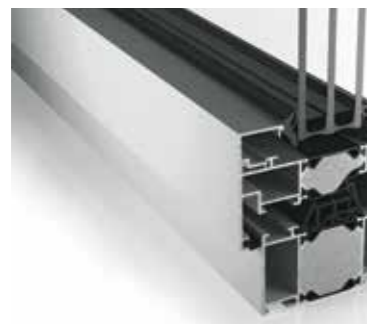

heroal W 72 i / heroal W 77 i (block window system)

The heroal W 72 i and heroal W 77 i window systems unite architectural design and slim view widths. The heroal W 72 i offers maximum transparency, heat insulation and an elegant design with no visible casements or glass strips. The block window system can be used in a variety of applications, including as a curtain wall insert element. Its combination with concealed system fittings provides for an elegant design. The block window system can also be designed as a floating window.



Floating window

The fusion of the curtain wall profiles with the special frames of the window systems creates the impression of a window elegantly floating in the curtain wall construction. This solution is available for the heroal W 72 and heroal W 72 i window systems.

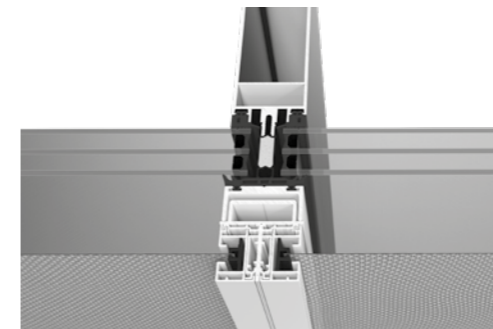

heroal VS Z CS (Semi-integrated curtain wall sun protection system)

To seamlessly integrate the heroal VS Z sun protection system into transom-mullion curtain walls such as the heroal C 50, heroal developed the heroal VS Z CS (curtain wall screen) with the heroal GR 25 guide rail. The system can be installed on conventional transom-mullion systems with a view width of at least 50 mm as a classic front-mounted installation using standard sun protection bolts. The heroal VS Z CS uses an integration profile as the mounting base, which can already be fabricated with the curtain wall mullions in the workshop.



heroal VS Z CS (Front-mounted curtain wall sun protection system)

To seamlessly integrate the heroal VS Z sun protection system into transom-mullion curtain walls such as the heroal C 50, heroal developed the heroal VS Z CS (curtain wall screen) with the heroal GR 37 guide rail. The system can be installed on conventional transom-mullion systems with a view width of at least 50 mm as a classic front-mounted installation using standard sun protection bolts. Crossbars in different lengths are used as the mounting base for the heroal VS Z CS. The individually adaptable distance to the curtain wall also allows installation in front of fall protection safeguards, for example.

Non-insulated profile systems for room partitions.

heroal window and door systems not only shape the building shell. They can also set accents indoors and enhance both design diversity and functionality with their outstanding properties. Wherever technical perfection and a timeless look are required, heroal profile systems are the right solution – as partition walls or double hung sashes. The innovative character of these high-quality systems makes it easy to bring modern, light-flooded room concepts to life.



Non-insulated heroal profile systems:

- + non-insulated windows, doors, sliding and fire and smoke protection systems
- + wide range of version and design options
- + accessible flat threshold
- + maximum compatibility and colour matching with the heroal system portfolio
- + variety of colours and designs with the heroal hwr powder coating
- + round, segmental and basket bends as well as circular elements

System dimensions

Description		heroal W 50 C	heroal S 50 C	heroal S 20 C	heroal D 50 C
Profile installation depth [mm]	Frame profiles	50	65/115	83/106/129	50
	Crossbar profiles	50	40	-	50
	Sash profiles	50/62	40	20	50
Profile view width [mm]	Frame profiles	53-150	47	45	53-150
	Crossbar profiles	68-250	68	-	68-250
	Sash profiles	35	70	60	73/95
Min. view width frame/sash profile [mm]		93	110	74 ⁴⁾	151
Sash profile variants	SBN ¹⁾	•	-	-	-
	KBN ²⁾	-	-	-	-
Max. glass/infill panel thickness [mm]	Frame profiles	34	-	-	-
	Sash profiles	44	22	10	34
Glass inset [mm]	Frame profiles	16	-	14/20	-
	Sash profiles	16	12	16	16
Max. casement weight [kg]		150	120	80	150
Max. sash height ³⁾ [mm]		2,800	2,100	2,200	2,250
Max. sash width ³⁾ [mm]		1,600	-	1,200	1,350/2,250

System features

Description	heroal W 50 C	heroal S 50 C	heroal S 20 C	heroal D 50 C
Air permeability	4	4	-	4
Tightness against driving rain	7A	5A	-	7A
Wind load resistance	C2/B2	C1/B2	-	C2/B2
Operating forces	1	1	-	1

Types of opening and versions

Description		heroal W 50 C	heroal S 50 C	heroal S 20 C	heroal D 50 C
Turn [D], tilt and turn [DK], tilt before turn elements [TBT]		•	-	-	-
Forend elements		•	-	•	-
Skylight elements [OL]		•	-	-	-
Fixed glazing	interior glazing	•	-	-	-
	exterior glazing	•	-	-	-
Swing doors	inward opening	-	-	-	•
	outward opening	-	-	-	•
Automatic doors		-	-	-	•
Anti-finger-trap doors		-	-	-	-
All-glass doors		-	-	•	•
Push-pull doors		-	-	-	•
Half-swing doors		-	-	-	•
Double-acting swing doors		-	-	-	•
French doors		-	-	-	•
Accessibility DIN 18040		-	-	•	•
System-compatible heroal system		heroal D 50 C	heroal W 50 C	heroal OR, heroal CR	heroal W 50 C
Fitting variants	heroal WF 100	•	-	-	-
	heroal WF 100 i	•	-	-	-
	heroal WF 200	•	-	-	-
	heroal WF 300	•	-	-	-

Design

Description	heroal W 50 C	heroal S 50 C	heroal S 20 C	heroal D 50 C
heroal hwr powder coating	•	•	•	•
Eloxal coating	•	•	•	•
heroal SD	•	•	•	•
Les Couleurs® Le Corbusier	•	•	•	•
Bending technology (formed elements)	•	•	-	•
Edging and laser machining	•	•	-	•

¹⁾ Push rod fitting groove

²⁾ Plastic fitting groove

³⁾ In combination with heroal WF fitting systems

⁴⁾ Frame and casement (bottom): 74 mm, frame only (side and top): 45 mm

⁵⁾ With 8 mm ESG 2,200 mm; with 10 mm ESG 2,500 mm

heroal W 50 C Economical partition wall system for indoors.

heroal W 50 C is the universal profile system for partition elements and wall systems, mainly for indoors. It is characterised by narrow view widths and can be used as a flush-mounted window or fixed glazing.

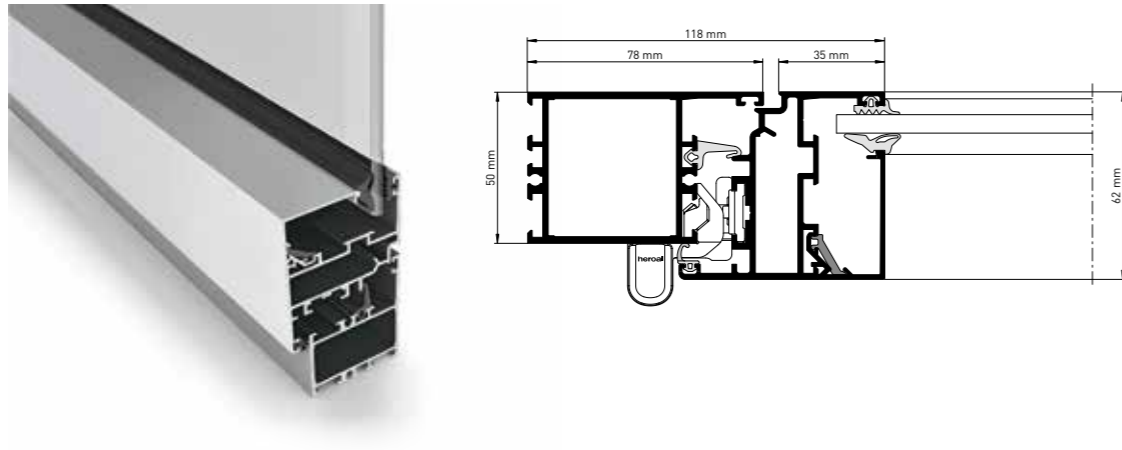

heroal S 20 C Sliding door system with frameless casements.

The non-insulated all-glass sliding door system is particularly flexible: the heroal S 20 C affords versatile opening options, with the frameless casements either sliding to one side or opening as a forend system. The 3-, 4- and 5-track thresholds can also be designed for full accessibility. The system is ideal for roofed outdoor areas.



heroal S 50 C System solutions for non-insulated sliding elements.

The heroal S 50 C is the attractive solution for sliding elements and doors, mainly for indoors. The system allows the implementation of 2- and 3-track sliding elements with up to 6 movable casements in narrow view widths.

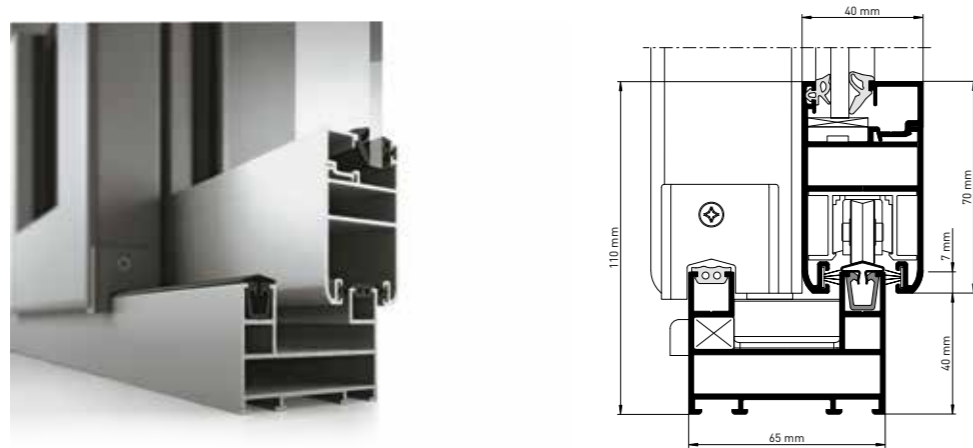

heroal D 50 C Efficient solutions for door and partition elements.

heroal D 50 C allows the implementation of a variety of types of opening for attractive and highly functional door and partition elements as well as partition wall systems, mainly for indoors. The variable flush-mounted external views create a wide range of design options.

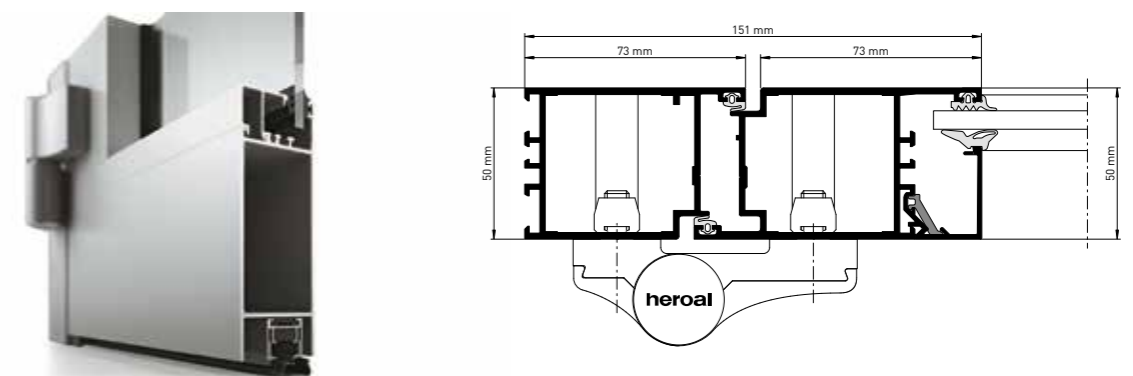

Sun protection systems for heat, glare and privacy protection.

The exterior, textile heroal sun protection systems allow modern residential and commercial construction requirements for efficient sun protection to be met in a wide variety of forms. The textile screens keep the room temperature pleasantly cool on hot days while still allowing in daylight and blend perfectly into the building shell. The portfolio includes sun protection systems for windows and doors in which the curtain is guided by a sturdy zip, a slimline stainless steel cable or discreetly via the end slat. Full integration into the curtain wall is also possible. In addition, heroal also offers horizontal and vertical awnings for use on outdoor roofs.



heroal sun protection systems:

- + textile screen either zip-guided, end slat-guided or cable-guided
- + more than 250 textiles ranging from nearly full transparency to full shading and darkening
- + aluminium components coated with the heroal hwr powder coating for perfect colour matching with the building shell
- + installation in flush-mounted, surface-mounted or front-mounted boxes
- + narrow guide rails (25 mm), optionally fully plastered
- + optimum textile tensioning even with extreme element dimensions

System dimensions

Description	heroal VS Z	heroal VS Z OR	heroal VS Z EM	heroal VS C	heroal VS	heroal HS (finished element)
Box system	FME, FMB		FME	FME	FME	FME
Box shapes	45°, 90°, HC N		90°	45°, 90°, HC N	45°, 90°, HC N	90°
Box sizes [mm]	85,95,105,125		85	85,95,105,125	85,95,105,125	165
Max. element width [mm]	6,000		2,000	5,000	5,000	5,000
Max. element height [mm]	5,000		2,200	5,000	5,000	3,000
Max. area [m ²]	18		4.40	15	15	15
Guide rails	•		•	-	•	•
End slats	Type I, II, III		Type I	Type II	Type II	HS type I, II

System features

Description	heroal VS Z	heroal VS Z OR	heroal VS Z EM	heroal VS C	heroal VS	heroal HS (finished element)
Wind-resistant [km/h]	up to 145		up to 65	up to 30	up to 30	up to 50
Hail impact class	6		6	6	6	-
Certified ball impact resistance	•		-	-	-	-

Versions

Description	heroal VS Z	heroal VS Z OR	heroal VS Z EM	heroal VS C	heroal VS	heroal HS (finished element)
Obstacle detection	•		-	•	•	•
Curtain control	Button, remote, crank		Button, remote	Button, remote	Button, remote	Button, remote
Drive type	Motor, handle, solar motor ¹		Solar motor ¹	Motor, solar motor ¹	Motor, handle, solar motor ¹	Motor
Smart Home	Remote control motor		-	Remote control motor	Remote control motor	Remote control motor
Installation	on wall/window, contra, lintel		clamped into window frame	on wall/window	on wall/window, contra	on outdoor roof / conservatory
Also available as heroal Ready finished element	•		•	•	•	•
heroal C 50 curtain wall system	•	-	-	-	-	-
heroal OR outdoor roof	•		-	-	-	•
heroal CR outdoor roof	•	-	-	•	•	•
heroal C 50 WG conservatory	•	-	-	•	•	•
heroal W 72/W 77 window system	•	-	•	•	•	-
90° corner solution	•	-	-	-	-	-

¹⁾ on request

Design

Description	heroal VS Z	heroal VS Z OR	VS Z EM	heroal VS C	heroal VS	heroal HS (finished element)
heroal hwr powder coating	•		•	•	•	•
Eloxal coating	•		-	•	•	-
heroal SD	•		•	•	•	•
Les Couleurs® Le Corbusier	•		•	•	•	•

Textile

Description	heroal VS Z	heroal VS Z OR	heroal VS Z EM	heroal VS C	heroal VS	heroal HS (finished element)
Textiles and colours	more than 250		more than 250	up to 250	up to 250	up to 100
Opening factor [%]	0 / 1 / 3 / 3.5 / 4 / 5 / 8 / 10 / 14					0 / 4
Reduction of up to [%] ²⁾	Solar radiation		100	100	75	75
	UV radiation		100	100	98	98

Fabric selection

Sergé and Satiné

are made of woven and coated fibre glass – the fibre glass core and the PVC coating make the fabrics particularly smooth and creates a pleasant atmosphere. Depending on the chosen textile, the different levels of transparency range from virtually transparent through to complete darkening.

Soltis

retains its shape particularly well. The textile is pulled in both directions under high tension and fixed in place with liquid PVC. The high textile tension makes the fabric ideal for shading large areas and for complete room darkening.

Orchestra

is woven from spun-dyed acrylic fibres and provides optimised performance features in terms of colour stability, resistance level and sun protection. The exclusive “Cleanguard” coating makes these textiles exceptionally water- and dirt-repellent.

Flexilight 6002 Opaque

is particularly resistant to UV radiation and has a dirt-repellent texture – so it keeps its good looks even after many years of use. The PVC fabric is phthalate-free, very easy to process and extremely flexible.

“colour design diversity” brochure

The brochure gives you an overview of the available fabric types and colours.



“colour design diversity” brochure

²⁾ Depends on the textile

heroal VS Z Zip screen system for high wind stability.

The versatile heroal VS Z is an innovative and energy-efficient zip screen system. It is used both in private construction and in medium- and large-scale commercial construction and is particularly suitable for use in schools, offices and residential buildings. The heroal VS Z is installed in front of the window and can provide either translucent sun protection or full shading. By reflecting the sunlight, the system makes it possible to reduce solar radiation by up to 100%* (depending on the choice of textile) without having to do without natural daylight.



heroal VS C Sun protection system with stainless steel cable guide.

The heroal VS C sun protection system comes with a slimline stainless steel cable guide, which makes this version ideal for windows and curtain walls with profiles with a narrow view width. The slender appearance of the entire system perfectly matches with the excellent heroal design language – the high-quality stainless steel cables impress with their minimalistic look. The heroal VS C reduces solar radiation by up to 98%* (depending on the textile selection).



heroal VS Z EM Reversible sun protection system with solar drive.

The heroal VS Z EM (Easy Mount) sun protection system is the clamp-on version of the heroal VS Z textile zip screen system. It can be installed without drilling and can be removed without a trace if needed. The integrated solar-powered drive makes the system ideal for retrofitting and it is also easy to use in heritage listed buildings, rental properties and existing properties. Various clamping support options enable the versatile use of the system in almost all common aluminium, plastic and wood window types.



Scan and view film



heroal VS Textile sun protection system with end slat guide.

Anyone looking for a basic version of the zip-guided heroal VS Z need look no further than the heroal VS sun protection system: one of the differences to the heroal VS Z zip screen system is the curtain guide exclusively via the end slat. This makes this sun protection system ideal for applications in which wind resistance does not play a significant role. The fabric selection can be used to provide either translucent or opaque sun protection that reduces solar radiation by up to 98%* (* depending on the choice of textile).



heroal HS Horizontal awning for patio roofs and conservatories.

As a horizontal awning for onglaze applications, the heroal HS can be perfectly combined with the heroal OR outdoor roof system or the heroal C 50 WG conservatory system. The textile sun protection system provides effective protection against strong solar radiation. The minimal space required enables the subtle integration of the sun protection for every type of application. For maximum textile tension, in addition to the zip guide, heroal HS is stretched by a tensioning system to provide shade for a maximum width of 5 m.

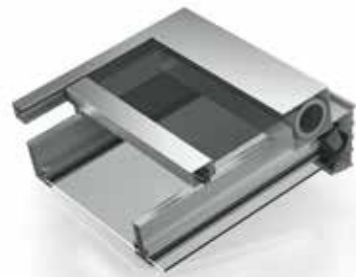

heroal VS Z OR Fully-integrated application in the heroal OR patio roof.

The zip-guided heroal VS Z OR sun protection system can be fully integrated into the heroal OR outdoor roof system as a vertical awning. It provides protection when the sun is low in the sky, protects against wind and weather as well as cool breezes on spring and autumn evenings. The heroal VS Z OR sun protection system provides outstanding weather protection thanks to the high wind load resistance. The fully-integrated installation in the heroal OR outdoor roof system ensures a harmonious design. The guide rails are recessed in the column and the panel box disappears in the eave. Maximum spans of 6,000 mm wide and 3,000 mm high are possible without a centre column.



Complementary solutions. Functional and versatile.



Scan and view film

heroal VS Z corner solution

The heroal VS Z corner solution consists of two textile screens with zip guide on the sides and a cable guide in the corner area that ensure efficient sun protection at corners (e.g. all-glass corners). A particularly clever feature: The curtain is guided with separate end strips, both of which run in just a single cable guide. This means that the screens can be controlled independently of each other and variably adjusted to the position of the sun.

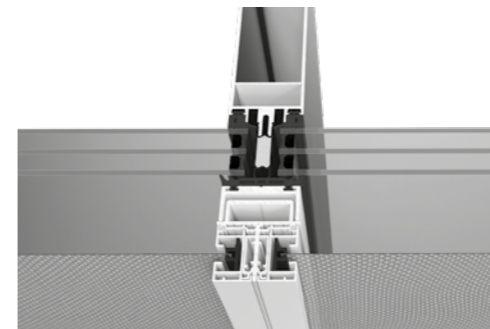

heroal VS Z CS (Semi-integrated curtain wall sun protection system)

To seamlessly integrate the heroal VS Z sun protection system into transom-mullion curtain walls such as the heroal C 50, heroal developed the heroal VS Z CS (curtain wall screen) with the heroal GR 25 guide rail. The system can be installed on conventional transom-mullion systems with a view width of at least 50 mm as a classic front-mounted installation using standard sun protection bolts. The heroal VS Z CS uses an integration profile as the mounting base, which can already be fabricated with the curtain wall mullions in the workshop.



heroal VS Z CS (Front-mounted curtain wall sun protection system)

To seamlessly integrate the heroal VS Z sun protection system into transom-mullion curtain walls such as the heroal C 50, heroal developed the heroal VS Z CS (curtain wall screen) with the heroal GR 37 guide rail. The system can be installed on conventional transom-mullion systems with a view width of at least 50 mm as a classic front-mounted installation using standard sun protection bolts. Crossbars in different lengths are used as the mounting base for the heroal VS Z CS. The individually adaptable distance to the curtain wall also allows installation in front of fall protection safeguards, for example.

Sun protection textile assembly for ready installation with the Exte Elite XT top-mounted box

The heroal VS Z textile assembly consists of a prefabricated textile from the current heroal collection, a cut-to-size textile roller shaft, an installed motor from the heroal range as selected by you and a pre-assembled end slat type III as well as all required accessories, such as roller caps and motor mounts. It can be installed in the Exte Elite XT box, is delivered to the customer ready for installation and can be put into operation immediately (plug and play).



Roller shutter systems for greater security and comfort.

heroal roller shutter systems made of aluminium and stainless steel impress with their durability, sustainability and design. The durable roller shutter slats made from recycled materials are coated with a durable 2-layer thick coating, which is even certified for use on ships, and are roll-formed in our own production facilities. Thick walls and medium- to high-density foam filling of the roller shutter slats make them extremely stable and burglar-resistant (up to RC 3) while also ensuring optimum winding behaviour so that even large elements only require small box sizes. Thanks to the wide variety of components and design options, heroal can offer the right solution for almost all construction or building refurbishment projects – whether as a front-mounted, top-mounted or flush-mounted roller shutter and with manual or motorised operation and even connection to a smart home system.



heroal roller shutter systems:

- + large selection of roller shutter slats made of aluminium and stainless steel
- + wide range of roll-formed and extruded roller shutter panels
- + harmonious design for linked elements thanks to continuous panel
- + with optional integrated insect screen
- + burglary resistance up to resistance class RC 3
- + small panel boxes thanks to tightly winding slats
- + hail impact up to class 7

Slat systems

Description	heroal RS 32	heroal RS 37	heroal RS 37 SL	heroal RS 37 RC 2	heroal RS 37 RC 3	heroal RS 38
Covering width [mm]	32	37	37	37	37	38
Nominal thickness [mm]	8.5	8.0	9.5	9.5	9.5	9.0
Finished curtain weight [kg/m ²]	4.8	3.5	5.9	8.8	15.0	4.5
Max. width [mm]	3,500	3,000	4,000	4,200	5,000	3,700
Max. height [mm]	3,500	3,500	4,000	4,000	4,000	3,800
Max. area [m ²]	7.5	6.2	9.0	10.5	12.0	8.0
Wind load resistance ¹⁾	2	1	4	4	6	3
Burglary resistance [RC] ²⁾	-	-	SL	RC 2	RC 3	-
Hail impact class ³⁾	4	4	5	7	7	4
Optimised noise insulation [dB]	+10	+10	+10	+10	+10	+10
Possible overall U-value improvement of up to [%]	42	42	42	41	56	42
Available as heroal Ready finished element ⁴⁾	-	•	•	•	•	•
Available as finished curtain	•	•	•	•	•	•
Version	Aluminium	Aluminium	Aluminium	Aluminium	Stainless steel	Aluminium

Description	heroal RS 41	heroal RS 41 SW	heroal RS 42	heroal RS 52	heroal RS 55 SL	heroal RS 53 RC 2
Covering width [mm]	41	41	42	52	55	52
Nominal thickness [mm]	8.5	8.0	9.3	13.5	14.0	14.0
Finished curtain weight [kg/m ²]	3.7	3.7	3.9	4.0	5.0	10.5
Max. width [mm]	3,500	3,500	3,500	4,500	5,000	5,500
Max. height [mm]	3,500	3,500	3,500	3,800	4,000	4,000
Max. area [m ²]	7.0	7.0	7.0	9.0	12.0	16.5
Wind load resistance ¹⁾	2	2	2	4	5	6
Burglary resistance [RC] ²⁾	-	-	-	-	SL	RC 2
Hail impact class ³⁾	4	4	3	5	5	7
Optimised noise insulation [dB]	+10	+10	+10	+10	+10	+10
Possible overall U-value improvement of up to [%]	43	43	43	41	43	42
Available as heroal Ready finished element	-	•	•	•	•	-
Available as finished curtain	-	•	•	•	•	•
Version	Aluminium	Aluminium	Aluminium	Aluminium	Aluminium	Aluminium

Box systems

Description	Front-mounted panel systems	Flush-mounted blind systems	Security panel systems
Box system	FMR, FME	FMB	FMS
Box shapes	20°, 45°, 90°, HC, Q ⁷⁾	20°, 45°, 90°	45°
Box sizes [mm]	125 - 230 ⁴⁾	125 - 205	205
Inspection type	front, bottom	bottom	front, bottom
Structural attachment	-	•	-
Insect screen integratable	•	•	-
Anti-push-up device can be integrated	•	•	•
Hail impact class	6-7	-	7
Burglary resistance [RC] ²⁾	-	-	•

Design

Description	heroal RS 32, heroal RS 37, heroal RS 37 SL, heroal RS 37 RC 2, heroal RS 38, heroal RS 41, heroal RS 41 SW, heroal RS 42, heroal RS 52, heroal RS 55 SL, heroal RS 53 RC 2	heroal RS 37 RC 3
hwr powder coating	-	-
2-layer thick coating	•	-
Eloxal coating	-	-
heroal SD	-	-
Les Couleurs® Le Corbusier ⁴⁾	-	-

Description	Front-mounted panel systems	Flush-mounted blind systems	Security panel systems
heroal hwr powder coating	•	•	•
2-layer thick coating	•	•	-
Eloxal coating	-	-	-
heroal SD	•	•	•
Les Couleurs® Le Corbusier	•	•	•

¹⁾ For 2,700 mm element width and a guide with 25 mm insertion depth, for heroal RS 37 RC 2 and heroal RS 37 RC 3 with 40 mm insertion depth, for heroal RS 52 RC 2 with 51 mm insertion depth
²⁾ SL, the roller shutter slat satisfies technical guideline TR 111 published by the Bundesverband für Rollladen und Sonnenschutz association for roller shutters and sun protection BVRS RC 2/RC 3, the roller shutter slat satisfies DIN 1627
³⁾ Hail impact class as per VKF test regulations no. 02
⁴⁾ Box size 230 mm for FMR 45° only, box size 125 mm not for FMR Q, box size 125 mm not for FMR HC, 125 mm not for FME HC
⁵⁾ Depending on the version
⁶⁾ On request
⁷⁾ Box shape Q not available as FME version

heroal front-mounted roller shutters

heroal front-mounted roller shutter systems with visible box are installed in front of the window. Thanks to the small winding diameter and the large selection of front-mounted boxes in various sizes, the system can be perfectly integrated into the curtain wall. Colour accents can be set thanks to the large selection of colours. The system can be optionally equipped with an integrated insect screen.



heroal top-mounted roller shutters

Top-mounted roller shutter systems are installed on top of the window and offer top insulation performance and simple installation. heroal roller shutter curtains can be combined with all standard top-mounted boxes and mounted on window and door systems. Special applications such as lifting-sliding door systems are also possible.



heroal security roller shutters

Thanks to their extremely stable and resilient roll-formed stainless steel roller shutter slats, heroal security roller shutter systems are certified up to resistance class RC 3 in accordance with DIN 1627. heroal Ready RS 37 RC 3 FMS can be implemented with certified element dimensions of a maximum width of up to 1,920 mm and a maximum height of 2,140 mm.



Complementary solutions. Functional and versatile.



heroal IS (insect screen system)

The high-quality heroal system solution is designed for the space- and material-saving integration of an insect screen into the roller shutter box and can be installed easily, quickly and economically. The insect screen is installed together with the roller shutter directly during the installation of the box and is fitted with a special guide rail for easy and reliable operation by hand independent of the roller shutter.

heroal rescue powered by Kaiser Nienhaus (2nd escape route)

The 12 V emergency power control system heroal rescue powered by Kaiser Nienhaus with an integrated lithium-ion battery enables the secure operation of heroal roller shutter and sun protection systems in the event of a power failure. This allows the roller shutter curtain or sun protection textile to be quickly and easily raised even in case of fire. The heroal VS, heroal VS C and heroal VS Z sun protection systems merely need additional carriers and adapters.

Roller shutter systems for more clearance.

First-class materials, technical perfection down to the last detail and a wide range of design options are what distinguish the efficient heroal roller door systems. Whether roller doors, roller grilles or overhead doors, high-quality aluminium alloy is used as the material. heroal roller door systems are TÜV-tested and CE-certified and achieve the best results in terms of opening and closing speed, energy efficiency, service life, protection against hail and storms, and soundproofing. The high-quality heroal hwr powder coating and the 2-layer thick coating ensure the weather resistance and durability of the roller door systems.



heroal roller door systems:

- + roller and overhead doors and roller grilles
- + TÜV-tested and CE-certified
- + wide range of equipment options and design variants
- + high wind load and hail impact resistance
- + optimised noise insulation

System dimensions

Curtain	Roll-formed						Extruded						
	heroal RD 55		heroal RD 75		heroal OD 75		heroal RD 75 E		heroal RG 90				
Installation type	Closed installation	Open installation	Closed installation	Open installation	Open installation with gear motor	Installation with lateral drive	Installation with centre drive	Closed installation	Open installation	Open installation with gear motor	Closed installation	Open installation	Open installation with gear motor
Covering width [mm]	55		75		75		75		91				
Nominal thickness [mm]	14		20		20		20		14				
Max. clear width [mm]	3,500		5,750	6,000	2,750	4,000	4,750	5,000	4,500				
Max. clearance [mm] ¹⁾	3,000		3,750	5,000	2,500	4,000	3,750	4,000	3,250	4,000			
Max. area [m ²]	10.5		16		6.8	16	21		14.6	18			
Min. lintel height [mm] ⁴⁾	231/252	293	305/367	293	65	100	367	405	305	320	390		

Description	Roller door slats						
	heroal RS 55 SL	heroal RD 75	heroal RD 75 TL (Trend Lines) with grooves	heroal RD 75 E (Extruded)	heroal RD 75 see-through and grill profile ⁵⁾	heroal RD 75 ventilation profile ⁵⁾	heroal RG 90
Covering width [mm]	55	75	75	75	75	77	91
Nominal thickness [mm]	14	20	20	20	20	15	14
Max. width [mm]	3,500	6,000	6,000	6,000	6,000	6,000	4,500
Max. height [mm]	3,000	5,000	5,000	5,000	-	-	4,000
Max. area [m ²]	10.5	16	16	21	-	-	18
Finished curtain weight [kg]	5.0	5.7	5.7	10.0	-	-	8.0

System features

Description	Roll-formed			Extruded	
	heroal RD 55	heroal RD 75	heroal OD 75	heroal RD 75 E	heroal RG 90
Wind resistance class ³⁾	1	4	4	4	-
Hail impact class ⁴⁾	5	6	6	6	-

Versions

Description	Roll-formed			Extruded	
	heroal RD 55	heroal RD 75	heroal OD 75	heroal RD 75 E	heroal RG 90
See-through, grille and ventilation profiles	-	•	•	•	-
Cabin hook locking device	-	•	-	-	-
Anti-push-up device	-	•	-	•	•
Hollow section end slat	•	•	-	•	-
Sliding barrel system	-	•	-	•	-
Anti-fall device	•	•	-	•	•
Emergency hand crank	•	•	-	•	•

Design

Description	Roll-formed			Extruded	
	heroal RD 55	heroal RD 75	heroal OD 75	heroal RD 75 E	heroal RG 90
heroal hwr powder coating	-	-	-	•	•
2-layer thick coating	•	•	•	-	-
Eloxal coating	-	-	-	-	-
heroal SD	-	-	-	-	-
Les Couleurs® Le Corbusier	-	-	-	•	•

¹⁾ Overall height (mm) for heroal OD 75

²⁾ With 2,500 mm curtain height

³⁾ Wind resistance class acc. to DIN EN 13241 at a clear width of 3,000 mm

⁴⁾ Hail impact class as per VKF test regulations no. 02

⁵⁾ The number of see-through, grille and ventilation profiles in a roller door is limited

⁶⁾ Specifications per box size

heroal RD 55 roller door Narrow system with small barrel diameter.

The roll-formed slat of the heroal RD 55 is a slim and particularly tightly winding roller door slat for element widths up to 3,500 mm. The system can be installed either open or in a closed box system. With a maximum curtain height of 3,000 mm, the barrel diameter on an 8K axle with a diameter of 70 mm is around 234 mm and is therefore suitable for box sizes from 230 mm.



heroal OD 75 overhead door Overhead door for garages with a low lintel height.

This system with a slat covering width of 75 mm enables the use of a very wide range of products in overhead doors. Thanks to its numerous slat and equipment variants, the system allows the realisation of tailor-made solutions for every installation situation. The centre drive makes overhead doors with large formats possible even with low lintel heights of just 135 mm. Thanks to the central power transmission on the curtain, the heroal OD 75 overhead door with element dimensions of up to 4,000 x 4,000 mm can be operated safely and reliably – even under heavy loads.



heroal RD 75 roller door Space-saving solution for large roller doors.

This system with a slat covering width of 75 mm provides a very wide range of products for use in roller doors. Thanks to its numerous slat and equipment variants, the system allows the realisation of tailor-made solutions for every installation situation. The closed installation of the roller door in the panel box is elegant in design while protecting the door from environmental influences. Thanks to the wide range of equipment options, this type of installation is ideal for both private and commercial use.



heroal RG 90 Roller grilles as a secure system solution for commercial buildings.

The heroal RG 90 roller grille system is perfect for commercial buildings with high security requirements, such as banks and jewellery shops. The system also allows operators to check underground car parks, for example, while simultaneously allowing access and the exchange of air. The curtain consists of fully extruded profiles, making it extremely stable. Thanks to their closed installation in the panel box, the roller grilles can be elegantly adapted to the existing architecture.



Complementary solutions. Functional and versatile.



Anti-push-up device

Burglar-resistant and gentle on the curtain – the three-part anti-push-up device for the heroal RD 75 roller door system with added textile protects the curtain against abrasion and makes it difficult to open it manually under pressure. Also available as direct axle attachment.



Anti-fall device

The ball bearing-mounted safety device catches and supports the curtain safely on all heroal roller door systems as an emergency measure in case of an uncontrolled unwinding.



Guide rail with cabin hook locking device

A perfect combination: the guide rail heroal URF 100 and the locking device of the heroal RD 75 slat provide increased stability and thus additional burglary resistance and maximum wind load resistance.



Emergency hand crank

When there is no second exit available: the emergency hand crank allows the user to open and close the door manually if the door can't be operated normally and there is no other way to leave the premises. Different variants enable installation to suit the application, such as exterior and lockable solutions. Available for all heroal roller door systems.



Curtain with hollow section end slat

The hollow section end slat gives wider doors additional stability and optimum guidance of the curtain in the rails. Available for roller door systems heroal RD 55 and heroal RD 75 – integrated from clear widths > 3,750 mm. A strengthening profile is likewise included as a standard component across all widths for the heroal RG 90 roller grille system.



See-through, grille and ventilation profiles

For greater ventilation or more light, the roller door curtain can be supplemented with see-through, grille and ventilation profiles – with colour accents also possible to enhance the design.



Sliding barrel system

Open installation with sliding barrel system for the heroal RD 75 roller shutter system: flexible positioning of the axle for optimum winding behaviour, particularly suitable for high elements. The sliding barrel system is automatically included in heroal prefabricated doors from clearances of 4,000 mm and is always integrated in open installations with geared motor.

Roofing systems for more living space.

heroal aluminium roofing systems are used to create stylish conservatories, patio roofs, canopies and carports. The systems offer architects and planners maximum freedom of design. With a span of over 7 m, the heroal OR outdoor roof system provides unrestricted panoramic views with no central support and without the need for a steel reinforcement. This makes heroal roofing systems ideal for use in the catering and hotel industry. With the right supplementary systems, use is also possible in any weather.



heroal roofing systems:

- + extreme widths of 12 m (up to 7 m without central support and steel reinforcement)
- + slimline, modern solution for roofed patios in residential and commercial buildings
- + can be extended with sun protection, awning, all-glass sliding door and other systems
- + integrated drainage and concealed rafter heads
- + wide range of design options for floor plans, structure, roof

System dimensions

Description		heroal CR	heroal OR		heroal C 50 WG	heroal C 50 TC
			heroal OR SL	heroal OR GL		
Design depths [mm]	Eave	160	180		137	60
	Columns	67.5-138	202		132	-
	Rafters	115-155	125	155	120-165	60
View widths [mm]	Eave	127	225	275	170	100
	Columns	106	202		106	-
	Rafters	75-86	inside 87 / outside 37		50	50
Max. element width [mm]		6,000 (2 columns)	7,200		13,000	no restriction
Roof pitch [°]		min. 5	7-30		min. 7	min. 15
Glass/infill panel thickness [mm]		up to 32	8-32		up to 44	12/16

Complementary systems

Description	heroal CR	heroal OR	heroal C 50 WG	heroal C 50 TC
heroal S 20 C all-glass sliding door system	•	•	-	-
heroal HS horizontal awning	•	•	•	-
heroal VS Z OR vertical awning	-	•	•	-
heroal window systems	•	•	•	-
heroal sliding and lifting-sliding door systems	-	-	•	-
heroal sun protection systems	•	•	•	-
heroal insect screen systems	-	-	•	-
heroal C 50 SW skylight window system	-	-	•	-

Design

Description	heroal CR	heroal OR	heroal C 50 WG	heroal C 50 TC
heroal hwr powder coating	•	•	•	•
Eloxal coating	•	•	•	•
heroal SD	•	•	•	•
Les Couleurs® Le Corbusier	•	•	•	•

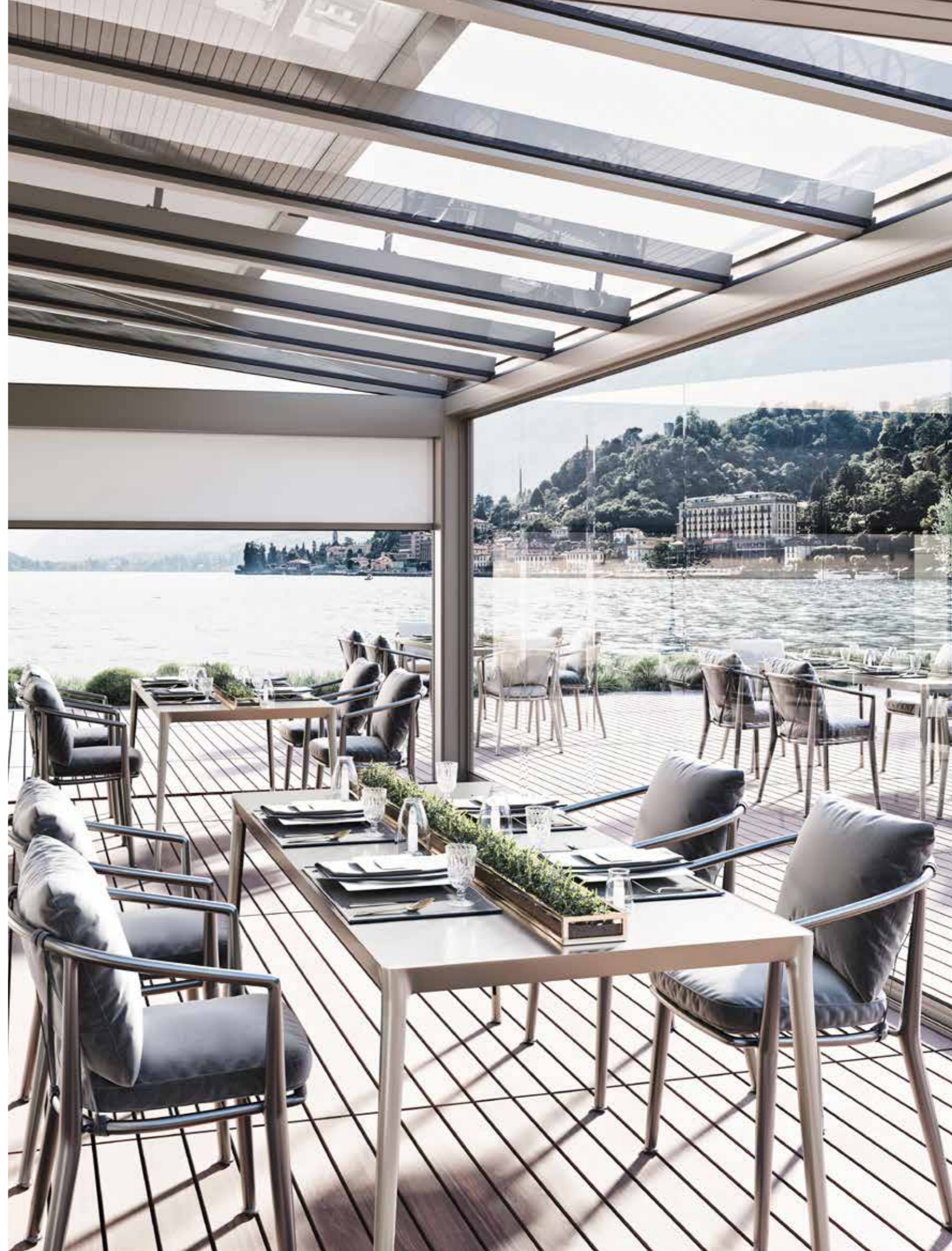

heroal CR System solution for outdoor roofs and carports.

The heroal CR system for the creation of outdoor roofs and carports impresses with its modern softline design, ease of installation and economical, simple production. The extensive range of heroal system accessories ensures a wide range of design options and guarantees maximum system reliability when it comes to load-bearing capacity and tightness.



heroal OR Timeless roofing system with large spans.

Thanks to its cubic construction with concealed rafter heads, the heroal OR roofing system offers a complete solution in a modern design. It is suitable for use in catering (heroal OR GL) and for roofed patios in private residences (heroal OR SL). Perfectly matched add-on systems like the heroal HS horizontal sun protection system, the heroal VS Z OR vertical sun protection system and the heroal S 20 C all-glass sliding door system make it possible to stay outdoors in any weather.



heroal C 50 WG Conservatory made from the heroal C 50 curtain wall system.

The versatile heroal C 50 curtain wall system can be used to create the heroal C 50 WG conservatory, which is a thermally insulated system allowing use as a living space. The conservatory can be connected to the curtain wall or to the structure. With a construction size up to 4.2 x 5 m, it can be designed without a central support. This enables the creation of spacious rooms, and the living space can even be extended later on. The vertical part of the conservatory system can be supplemented with insert elements from the entire heroal portfolio. The roof area can be fitted with the heroal C 50 SW skylight window.



heroal C 50 TC Canopy from the heroal C 50 curtain wall system.

The versatile heroal C 50 curtain wall system can be used for the installation of the high-quality heroal C 50 TC canopy in upscale residential and commercial buildings. With a maximum reach of 2,000 mm and an adjustable roof pitch, the canopy can be customised to suit individual requirements. The canopy is firmly connected to the curtain wall or structure. Loads of up to 6.5 kN are transferred per support. The slim profiles with a 60 x 50 mm rafter profile and a 50 x 50 mm support profile create slimline views. Thanks to sharing the same surface, the canopy and curtain wall can share the same design. The end caps are also available in different colours to harmonise with the overall look.



Complementary solutions for heroal OR.

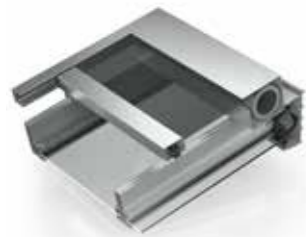

heroal HS (horizontal awning)

The heroal HS textile sun protection system protects the roofed space from heating up when exposed to strong solar radiation and can be harmoniously integrated. In addition to a zip guide, the sun protection system is also stretched using a back pull system. The system can also be integrated into the outdoor roof system.



heroal VS Z OR (vertical awning)

The zip-guided heroal VS Z OR sun protection system can be fully integrated into the heroal OR outdoor roof system as a vertical awning. The heroal VS Z OR provides outstanding weather protection thanks to the high wind load resistance. The fully-integrated installation in the heroal OR outdoor roof system ensures a harmonious design. The guide rails are recessed in the column and the panel box disappears in the eave. Maximum spans of 6,000 mm wide and 3,000 mm high are possible without a centre column.



heroal S 20 C (all-glass sliding door system)

The non-insulated heroal S 20 C all-glass sliding door system allows roofed outdoor areas to be used regardless of wind and weather. The heroal S 20 C sliding system offers a wide range of opening options. The frameless casements give the sliding door a particularly elegant design and maximum transparency. A freely accessible threshold, sliding dampers, casement carriers and the durable stainless steel runner ensure additional comfort.

Complementary solutions for heroal C 50 WG.



heroal C 50 SW (skylight window)

The heroal C 50 SW (Skylight Window) system is an outward-opening skylight window that can be integrated as an insert element in the heroal C 50 WG conservatory or in the heroal C 50 curtain wall system and is suitable for all roof pitches. The heroal C 50 SW can be operated manually or electrically on request. It is also possible to connect it to a central control system for automatic ventilation. Drainage and ventilation of the skylight window is ensured via the conservatory or curtain wall system.



heroal sliding and lifting-sliding doors

heroal sliding and lifting-sliding systems blend harmoniously into the heroal C 50 WG conservatory and allow unrestricted access to the outside. As standard, the systems offer a high level of heat insulation allowing modular adaptation, flexible opening options and perfect colour matching with the heroal C 50 WG thanks to heroal hwr powder coating. Tried-and-tested heroal technologies also guarantee optimum comfort, air permeability, tightness against driving rain, accessibility and burglary resistance.



heroal window systems

heroal window systems can be integrated into the heroal C 50 WG conservatory as insert elements. As French doors, optionally including the heroal DS drainage system, heroal window systems also enable full accessibility to the outside. Thanks to the large selection of designs, types of opening, colours and designs, the window systems can be perfectly adapted to the conservatory and to individual requirements. Various equipment variants allow for maximum flexibility in terms of heat insulation, soundproofing and burglar-resistance.



heroal sun protection systems

heroal's textile vertical and horizontal awnings provide effective shading for the heroal C 50 WG conservatory. The external sun protection systems prevent direct solar radiation, provide heat, glare and UV protection, and prevent the roofed room from heating up. The vertical awnings can be semi-integrated or mounted in front of the conservatory. Numerous textiles and the heroal hwr powder coating afford unlimited possibilities for harmonious design.

References



Education & Science: Folkwang Library
Essen, Germany

» heroal C 50 curtain wall system

» fabricator: Wigger Fenster + Fassaden GmbH





Read project report online

Education & Science: Fritz-Henßler-Berufskolleg

Dortmund, Germany

System solutions by heroal for historic school building in Dortmund

After a construction phase of two and a half years, the history-charged Fritz-Henßler-Berufskolleg, a vocational training institution in the city centre of Dortmund, has been extensively refurbished and enlarged by two additional buildings. The result is a complex of school buildings satisfying all demands on a modern and future-orientated learning environment. From an architectural perspective, an exciting dialogue between old and new unfolds both inside and outside. Different system solutions by heroal give distinction to the new outer appearance of this group of buildings, while at the same time providing core features, such as thermal insulation. Numerous national and international awards the parties involved received for this project give evidence of the successful renovation and conversion of this building.

Starting signal for modern extension

The foundations of this listed building were laid down in the year 1904, and since then, it has already seen numerous refurbishments and conversions. Today, the vocational training college looks back on a building history of more than 100 years, characterised by continuous extensions that were added during different construction eras. Nevertheless, a considerable bottle neck of building renovation built up over the years. Therefore, it became

obvious in the year 2010: the vocational training college needed comprehensive refurbishment. It became equally clear that the existing space was not sufficient in order to meet today's needs. Therefore, right from the start, the extensive plans also included the construction of two new buildings which were to be integrated; considering aspects of both urban development and preservation of historic sites. The appearance of the imposing façade of the existing historic building served as a model for the



architectural style of the façades of the new buildings. Also, the existing building was a guideline for the arrangement and dimensional ratio of the wall openings for the new window elements and their partitions.

Innovative system solutions and historic old buildings in an exciting dialogue

The architects involved were especially concerned about preserving the existing listed building, which was in danger of demolition, as an important corner stone of the city of Dortmund. Hence the challenge of this project was to combine old and new building parts to be both a functional and aesthetically appealing building complex. Accordingly, the demands on the building materials to be used were quite high. In close cooperation with the architect, the executing metalworking business, the company Tesche in Lüdenscheid, decided in favour of the window system heroal W 72, the curtain wall system heroal C 50 and the door system heroal D 72. These heroal system solutions also convinced the managing architect Mr Frank Köller: "The heroal products used fulfil our high demands on quality and design. Especially the slim profiles and the look of the opening sashes, which seem to be almost frameless, are very convincing." In addition, the heroal systems used exceed the special ratings required for the construction elements, such as thermal insulation and sound protection. Also, the face widths of the profiles appeal, because of their narrow design. The system producer, the metalworking company and the architects worked closely together in order to create special solutions meeting the individual demands on the project. In addition, heroal's project service provided support and consultancy for all trades involved during all construction phases.

Formation of a future-oriented school building

The result is a building complex whose sophisticated architecture can be recognised at first glance: The existing historic building and the architectural design of the façades of the new buildings merge through the appealing transition achieved by the post-transom construction of the curtain wall system heroal C 50. The entrance area of the new building welcomes its visitors with its modern and open style; the door system heroal D 72 is ideally adapted to the high frequency of use of a school building. The filigree frames of the window system heroal W 72 discretely retreat into the background and grant the expansive window surfaces ample room to impress.

It almost appears as if they were floating-on-air. Additionally, the windows allow lots of light into the building and that way make a valuable contribution to a healthy and modern learning environment.



Numerous awards for a sophisticated concept

From day one, the refurbishment of the Fritz-Henßler-Berufskolleg was subject to the idea of sustainability. During the entire construction phase, all parties involved always focused on an intelligent planning that used the land efficiently and preserved resources, in order to minimise both investment and follow-up costs. For example, the embodied energy of the existing building was used to reduce production energy. The heroal systems used are ideally suited for this concept. They exceed all demands on thermal insulation and are innately sustainable. In practice this means: heroal systems are made from recycled aluminium and with best thermal insulation values actively contribute to an optimised energy balance of the building project. The successful implementation of the integral planning has received numerous national and international awards, for example the German School Design Award NRW.

Project information

- » building owner: City of Dortmund - Sondervermögen GVVF
- » planning / architects: SSP Architekten
- » fabricator: Tesche Metallbau GmbH
- » year of completion: 2018

heroal systems

- » heroal C 50 curtain wall system
- » heroal W 72 window system
- » heroal D 72 door system

Education & Science: Studentenwerk Göttingen

Göttingen, Germany

- » heroal D 82 FP fire protection door system
- » heroal C 50 curtain wall system
- » heroal W 72 window system
- » heroal D 65 C SP door system with smoke protection requirement
- » heroal D 72 door system

» fabricator: Pistorius Türen- und Fensterbau GmbH



Education & Science: Aalborg University

Esbjerg, Denmark

- » heroal VS Z sun protection system
- » fabricator: Alux A/S





Education & Science: Secondary school

Winsen (Luhe), Germany

- » heroal C 50 curtain wall system
- » heroal W 72 window system
- » heroal D 72 door system

» fabricator: BEKRU Werke Fenster- und Türen-Herstellung und Vertriebs GmbH



Education & Science: Day-care centre

Dinslaken, Germany



- » heroal C 50 curtain wall system
- » heroal W 72 window system
- » heroal D 72 door system
- » heroal D 65 C non-insulated partition system

» fabricator: Metallbau Funke GmbH & Co. KG





Scan and view film

Office & Administration: PhoenixWERK

Dortmund, Germany

New working in a historic context

In the city of Dortmund, situated between nature and historic industrial architecture, a building with innovative workspace is being created: PhoenixWERK. Its high-quality clinker brick façade adapts the look of the existing historic Phoenixhalle, a former factory building, and follows in on the tradition of the former foundry. With its clear orientation towards the historic blast furnace and Warsteiner Music Hall, it blends in naturally with the industrial architecture of the German Ruhr region.

Working amidst green oases and historic industrial architecture

Outside, PhoenixWERK blends in perfectly with the historic surroundings of the old PHOENIX West steelworks site, while inside it offers a prestigious and unique working environment. High-quality office space with spacious roof terraces on the upper floors and restaurants and bistros on the ground floor as well as an extensive outdoor area already add to the charm of the square called Phoenixplatz.

Sophisticated solutions by heroal – high-quality, modern and efficient

During construction, individual requirements of both tenants and investors are met with greatest flexibility.



The architectural concept for this neighbourhood also includes a car park in the immediate vicinity. The exclusive architecture focuses on a sustainable and eco-friendly construction, state-of-the-art technology and high-quality, exclusive materials – all of this lends style to the entire ensemble of office buildings. Therefore, the project managers at the German architecture firm SHA Scheffler Helbich Architekten GmbH decided on high-quality, sustainable solutions made by heroal.

During the tendering phase, heroal's Project Service provided support by getting in touch with the metal construction company Metallbauers Metallbau Lamprecht GmbH, in addition to selecting suitable systems. For the acceptance of tender, heroal's Project Service was just as important as the system solutions themselves. In total, PhoenixWERK was equipped with around 550 m² of the

curtain wall system heroal C 50 HI, 14 elements of the door system heroal D 72, 3 lifting-sliding systems heroal S 77, 172 windows of the system heroal W 72 and the concealed Siegenia fittings heroal WF 100 i.

Versatile product features are convincing

Promoting the sophisticated architecture of the project, not only does the energy efficiency of the aluminium systems play an important role, but also their design. The highly thermally insulated system solutions offered by heroal meet the highest demands on aesthetic looks, design and strong lines of modern architecture, and are perfectly suited for individual, sustainable buildings. To underline the industrial character of the building, the heroal systems installed are coated in RAL 9005 (deep black) using highly weather resistant heroal hwr powder coating technology.

Smooth running of works on site

The first two units of PhoenixWERK were completed in 2020. The fact that this project is running so smoothly is due, not only to the high-quality solutions and the committed skilled workers on site, but also to the close coordination between all parties involved.

Project information

- » building owner: SHA Scheffler Helbich Architekten GmbH
- » planning / architects: SHA Scheffler Helbich Architekten GmbH
- » fabricator: Metallbau Lamprecht GmbH
- » year of completion: 2020

heroal systems

- » heroal C 50 HI curtain wall system
- » heroal W 72 window system with heroal WF 100 i
- » heroal S 77 lifting-sliding system
- » heroal D 72 door system





Office & Administration: Technologiepark Paderborn

Paderborn, Germany

- » heroal C 50 HI curtain wall system
- » heroal W 72 window system
- » heroal D 72 door system

» fabricator: ISO Fensterbau GmbH



Office & Administration: Listed former brewery building

Untersteinbach, Germany

- » heroal D 72 door system
- » heroal W 72 i window system
- » heroal W 72 window system with round bends
- » heroal profile bending and sheet metal processing

» fabricator: Gugelfuss GmbH



Office & Administration: Kotelna Park II

Prague, Czech Republic

System solutions by heroal used for office complex in Prague

One of the most dynamic, vibrant business districts of the booming city of Prague currently evolves in the city's district 5. Architectural highlight: Even the most state-of-the-art office buildings are carefully integrated into the existing surroundings. For example, the office building Kotelna Park II, designed by the award-winning architects Chapman Taylor, successfully takes up the design of its sister complex Kotelna Park I completed in 2019 and built as a further re-development of the traditional Waltrovka Factory. One of heroal's customers, the Czech company RETRE, s.r.o., saw to the implementation of the building plans.



Office building with convenient extras

By spring 2020, 12.000 m² of office space with a view and a vision have been built. In the reception area located on the spacious ground floor of Kotelna Park II, visitors may be welcomed around the clock. A café is also to be found here, inviting visitors and occupants to stay. Above the ground floor, six flexibly designed floors offer future occupants a lot of working space. An additional two levels of underground car parking provides 140 parking places. In a nutshell, this complex is open to modern concepts of work and thus represents the office of tomorrow.

Coherent master plan with system solutions by heroal

This building with its futuristic appearance was expected to closely combine technology and the eco-friendly exploitation of resources. Sustainability plays a predominant role for the building concept. In addition, another focus was placed on light and flexibility inside. The ideal combination of these two objectives can also be seen outside. All floors of Kotelna Park II have been designed

with a circumferential curtain wall with large windows. Each floor has its own 20 m² terrace. The parking levels have green roofs creating a terraced podium. A rear garden offers a landscaped space which can be used by all occupants of the building. The building plans of Kotelna Park II provided for a total space of 770 m² for windows and 3,400 m² for curtain walls, offering an unobstructed view of the city of Prague. The developer chose window, door and curtain wall systems made by heroal.

Windows, doors and ventilation with a concept

The window system heroal W 72 was the system of choice. It perfectly meets the demands on this unparalleled urban office building – because it is innovative, sustainable, cost-effective and energy-efficient. The curtain wall was supplemented by ventilation flaps heroal W 72 VF, which offer numerous advantages. All ventilation



flaps can be opened and closed independent of users, which makes possible a controlled, natural ventilation around the clock. Just as required by the customer, they harmoniously integrate into the curtain wall, emphasizing the individual character by setting visual accentuations. The system solutions are rounded off by the project door system heroal D 72, which stands out in the highly frequented entrance area of Kotelna Park II.

Curtain wall offering additional advantages

A dream come true for planners, builder-owners and partners: A curtain wall with uncompromisingly efficient energy values and flexible design options. The curtain wall system heroal C 50 HI achieves excellent values for ventilation, thermal insulation and tightness, which is a most important aspect for an office building of this size. The curtain wall system by heroal leaves much freedom for individual design options. The special feature: the post-transom

curtain wall is designed with a radius, so that it is slightly curved. The ventilation flaps heroal W 72 VF with their wooden look set a visual accentuation in the curtain wall of Kotelna Park II – made possible by the coating technology heroal Surface Design (SD). This feature lends individuality to this harmoniously designed curtain wall.

Project information

- » proprietor: Jednatel Richard Henry Stewart Ness
- » planning / architects: Chapman Taylor s.r.o.
- » fabricator: Retre s.r.o.
- » year of completion: 2020

heroal systems

- » heroal C 50 HI curtain wall system
- » heroal W 72 window system
- » heroal W 72 VF ventilation flaps in heroal SD wood look
- » heroal D 72 door system



Read project report online



Office & Administration: Vejen Town Hall

Vejen, Denmark

» heroal VS Z sun protection system

» fabricator: Alux A/S



Education & Science: IT Campus

Paderborn, Germany

- » heroal C 50 curtain wall system
- » heroal W 72 window system
- » heroal D 72 door system

» fabricator: Scheffer Metallbautechnik GmbH





Read project report online

Office & Administration: heroal Forum

Verl, Germany

All under one roof: heroal Forum offers training facilities, offices and a bistro

It all started with the idea of offering heroal employees in Verl a place for joint breakfast and lunch breaks in a modern, yet cosy ambience. The result is a building that combines a variety of requirements: on three floors, the heroal Forum offers space for the heroal Bistro, opportunities for meetings, training courses and events, as well as additional office space for heroal employees. The open building architecture provides for various options to use this space, which sparks communication and the exchange of ideas. The offices are spacious and some of the interior walls can be moved to adapt the size of the rooms to individual requirements. Thus, heroal Forum completed in 2019, creates genuine additional value for visitors and employees on a total area of around 1,600 square metres.

heroal curtain wall systems: perfect thermal efficiency and maximum transparency

The heroal Forum is characterised by its transparent building shell with generous glass surfaces. At the same time the challenge was to design a building that would be as sustainable as possible. A constantly pleasant indoor climate in the building throughout the year in order to create a healthy working environment was also a priority. For this reason, the choice fell on systems that meet particularly high demands for thermal insulation while at the same time offering small face widths. Therefore, the curtain wall system heroal C 50 HI was used, which, thanks to its sophisticated profile design, achieves top values in terms of thermal insulation, resulting in considerable energy savings and an enhanced energy

balance for a building of this size. The slim mullion and transom profiles with a face width of 50 mm are characterised by excellent static values with a low profile weight. In combination with the heroal PS transom tensioning system, the profiles can support much higher glass loads than usual. In this way, it was possible to create above-average transom lengths and thus maximise the incidence of light in the heroal Forum - with constant face widths of the profiles and secure statics. In addition to the curtain wall system heroal C 50 HI, the upper floor of the heroal Forum was fitted with the glass mullion curtain wall heroal C 50 GD, where a glass fin replaces the classic aluminium mullion in terms of statics. This design is a real highlight for the facade: due to reflection, the face width as seen from the inside appears reduced, while the design depth of the mullion is visually reduced when looking at it from the outside. The generous glass surfaces provide for great transparency in the office spaces, creating a pleasant working environment with plenty of natural light.



heroal door systems: barrier-free entrance combined with sustainability and design

Light slabs of stone, lined by green hedges and Japanese maple, lead the visitor to the fully accessible entrances of the building. In order to ensure barrier-free access to the heroal Forum, door systems with a level, step-free threshold were installed. Since the entrance is situated at the weather side of the building, it was a challenge to protect it against the elements. The patented, seamlessly integrating drainage system heroal DS solved this problem: it creates fully accessible, step-free solutions, meeting the statutory regulations for accessible construction according to German industry norm DIN 18040-1 for public buildings and DIN 18040-2 for dwellings.

The heroal Les Couleurs® Le Corbusier front door directly leads to the staircase area. The residential and commercial front door system heroal D 72 is designed as floor to ceiling element, measuring 2,950 mm high and 1,300 mm wide. With the restrained colouring using the Les Couleurs® Le Corbusier shade gris 31 for door panel and handle, it unobtrusively blends in the building shell.

The automatic door system made from the door system heroal D 65 provides convenient and barrier-free access to the building and also serves as a wind lobby for the adjacent bistro area, where culinary and regional dishes are freshly prepared. Employees and guests of the company enjoy the daily changing dishes on offer and also use the heroal Bistro and the adjoining patio to relax or exchange ideas across departments.

The lifting-sliding door systems heroal S 77 SL used in the heroal Bistro create maximum transparency and a perfect room climate: thanks to the 3-chamber profile system with high thermal insulation in combination with double thermally separated profiles, heroal S 77 SL is extremely thermally efficient, despite its small face width. In addition, the lifting-sliding doors visually extend the room to the outside and create a feeling of open space, with rooms

flooded with light. The level stainless steel rail and the monorail sashes with heroal SF Drive motorised drive further increase convenience and living comfort: at the touch of a button, the lifting-sliding door opens automatically and offers barrier-free access to the outdoor patio - even if you don't have your hands free.

Outside sun protection: effective shading of the heroal Forum

The textile sun protection system heroal VS Z provides effective shading of the large glass surfaces in the heroal Forum, enabling glare-free working and a pleasant, constant indoor climate. The external sun protection not only offers the advantage of absorbing the light rays before they hit the glass, thus preventing the building from heating up, it can also be combined with the heroal C 50 curtain wall system: the innovative zip fastener technology fixes the blind over the entire length of the guide rails, which are attached to the curtain wall on traverses. The installation using traverses makes it possible to flexibly adjust the distance between the sun protection and the building structure. The system, certified for safety against ball throwing, easily withstands even high wind loads with wind speeds of up to 145 km/h - the equivalent of hurricane force 12 causing severe storm damage and devastation. When lifted, the sun protection almost completely disappears into the curtain wall, underlining the subtle design and modern look of the heroal Forum.

Architectural colour design in perfect harmony

In the heroal Forum, all heroal systems are designed in the exclusive shades of Les Couleurs® Le Corbusier. The nature-inspired colours evoke positive associations with their surroundings and can be combined with each other in a particularly harmonious way.

Project information

- » building owner: heroal – Johann Henkenjohann GmbH & Co. KG
- » architects: Architekturbüro Wischke Send + Partner
- » fabricator: Busmann Alubau GmbH
- » year of completion: 2019

heroal systems

- » heroal FireXtech D 93 FP fire protection door system
- » heroal C 50 HI and heroal C 50 GD curtain wall system
- » heroal W 72 and heroal W 72 UD window systems
- » heroal S 77 SL lifting-sliding door system mit heroal SF Drive
- » heroal D 72 and heroal D 65 door systems
- » heroal VS Z sun protection systems
- » heroal DS drainage system



Read project report online

Office & Administration: AC Group A/S

Viborg, Denmark

Modern office building with especially large-surface sun protection

In Viborg, the second-largest municipality in Denmark, the office building of AC Group A/S was completed in 2018. The city is centrally located and has a charming historic centre and some well-known churches, such as the Romanesque Viborg Cathedral. A number of different companies in the vehicle and hydraulics industries are based in the city's large industrial zone. The holding AC Group A/S is a market-leading craftsman's and repair business in the area of workshop and lorry cranes, also offering a wide range of lifting devices for the automotive industry. Therefore, the industrial zone of Viborg is the ideal location for the business and the new office building of AC Group A/S.

A substantial requirement on the office building is the creation of a comfortable and healthy room climate. With the ideal sun protection system, you can shade even large glass surfaces – for effective heat protection in the summer and heat insulation in the winter, as well as protection from unwanted prying eyes, looking into the office rooms. In order to meet these requirements, the textile sun protection system heroal VS Z was chosen. In addition to efficient protection from heat, prying eyes and glaring light, the heroal VS Z system is suitable to shade even large areas, offering sufficient wind stability. In close cooperation with the Danish heroal

fabricator ALUX A/S, the company AC Group A/S equipped its building with the sun protection system



heroal VS Z. The manufacturer heroal has many years of experience and reliable business partnerships in Scandinavia. Even special solutions, e.g. especially large elements, can be supplied, reliably and quickly. As a result, heroal sun protection systems are installed in a number of diverse, demanding building objects in Denmark, Norway and Sweden. Thus, the heroal fabricator ALUX A/S was able to integrate especially large sun protection elements when planning the office building of AC Group A/S.



Efficient and individual control of daylight

The zip screen system heroal VS Z is a versatile textile sun protection system. It withstands the most adverse weather conditions, moves quietly and provides the ideal protection from glaring light, at the same time making efficient use of daylight. Sizes and designs can be adapted to the most diverse requirements. By reflecting the sunlight, heroal VS Z makes it possible to reduce solar radiation by up to 75 per cent and aggressive UV radiation by even up to 98 per cent. In addition to effective protection from heat, the zip screen system by heroal offers privacy protection in order to avoid unwanted prying eyes, looking into the office building, as well as protection from blinding light in order to guarantee non-glare lighting of the rooms. That way, the heroal sun protection system is especially suited to be used in office buildings: AC Group A/S employees do not need to work without natural daylight, but also are not blinded by the sunlight when working at their workstations. A comfortable climate in the offices and convenient working conditions are ensured.

Owing to the water and dirt-repellent textile surface and the high wind resistance of up to 90 mph, the sun protection system is almost independent from weather. The sun protection elements are either manually

activated, by the push of a button, or via wireless control. They can be additionally equipped with wind and sun sensors.

A total of thirteen heroal VS Z elements was installed, all of them with especially large textiles in order to shade the office rooms optimally and create a comfortable room climate every day. Instead of the standard maximum height of 5,000 millimetres, the sun protection elements of this building project have a height of 5,750 millimetres.

Persuasive advantages for heroal fabricators

The extensive heroal customer service offers fabricators, planners and architects numerous design options and object-specific solutions – during each construction phase. This service offering enabled the fabricator ALUX A/S, to integrate especially large elements into the office building of AC Group A/S, quickly and easily. To meet the special requirements of the heroal customer ALUX A/S, the height of the sun protection elements for this project exceeded the standard by 750 millimetres.



Project information

- » building owner: AC Group A/S
- » planning / architects: ERIK arkitekter A/S
- » fabricator: ALUX A/S
- » year of completion: 2018

heroal systems

- » heroal VS Z sun protection system



Office & Administration: Aupers Ingenieure Münster, Germany

- » heroal W 72 window system
- » heroal D 72 and heroal D 65 door systems
- » heroal C 50 curtain wall system
- » heroal FireXtech D 93 FP fire protection door system
- » heroal D 65 C SP non-insulated smoke protection door system

» fabricator: TPM GmbH



Office & Administration: West-End-Carrè Paderborn, Germany

- » heroal C 50 HI curtain wall system
- » heroal W 72 window system
- » heroal D 72 door system

» fabricator: ISO Fensterbau GmbH



Hotel & Residential: Arborea Marina Resort

Neustadt, Germany

- » heroal C 50 curtain wall system
- » heroal W 72 window system
- » heroal S 77 lifting-sliding system
- » heroal D 72 door system

» fabricator: Gebr. Busmann Alu-Bau GmbH



Read project report online

Hotel & Residential: the niu Tab

Düsseldorf, Germany

- » heroal DS drainage system
- » heroal W 72 window system
- » heroal S 77 SL lifting-sliding system
- » heroal D 72 door system

» fabricator: Wigger Fenster + Fassaden GmbH

Hotel & Residential: G. residence

Wuppertal, Germany



Read project report online



heroal window and door systems create rooms flooded with light

Situated close to nature, a prestigious villa with a generous 351 m² of living space was built on the outskirts of the city of Wuppertal, Germany. Large windows and sliding door elements from heroal ensure maximum transparency and skilfully create a connection between the interior and exterior spaces. The following systems were used for this building: heroal W 72 windows, heroal D 72 doors and heroal S 77 SL lifting-sliding doors.

When the residents of the one-family house in Wuppertal, completed in 2018, wake up, they gaze at panoramic views of the spacious garden and the natural reserve with its meadows and woodlands beyond from windows that are as wide as the room. Generous proportions and transparency characterise the entire architecture of the building: rooms flooded with natural light facing the valley, a spacious entrance hall with an impressive front door and two large fixed glass sidelights, as well as lifting-sliding doors, panoramic windows and floor-to-ceiling French doors with fixed glass sidelights that offer new perspective views of the surroundings from every room.

Modernity in harmony with nature

After two years of planning and construction, a new, modern two-storey building was built on the 2,000 m², slightly sloping plot of a former factory owner's villa, designed by the Cologne-based architects oxen architekten according to the ideas of the new owners. In addition to a sustainable use of resources and building materials, the aim was to create a transparent building architecture, which can not be overlooked from the street and

still offers room for a retreat in everyday life through a clever arrangement of the different living areas. "The whole family comes together in the living area - but everyone also has their own personal retreat. The children's rooms are in the basement, as are a guest room and hobby room and the wellness area with sauna. The master bedroom is separated from the common rooms by the entrance hall," says the owner.

This separation can also be seen in the cubic building itself: different room heights and layouts underline the special charm of the property. At the same time, the building was to reflect the landscape and harmoniously unite architecture and natural surroundings. "We enjoy the view, the proximity to nature and the rooms flooded with light. The generous glass surfaces make the landscape part of our living areas - every room offers a different, interesting view of the green surroundings," explains the owner.

Rooms flooded with light with heroal window systems

The builder-owners chose aluminium windows from heroal and thus not only fulfilled their desire to use sustainable materials, but also opted for maximum flexibility and functionality. This is because the heroal W 72 window system made of recycled aluminium offers the best thermal



insulation, certified burglary protection and a wide range of designs, to name but a few outstanding features.

With their slim face width and concealed fittings, the window profiles visually recede into the background of the façade and, thanks to the large glass surfaces, emphasise the spacious view out of bright and light rooms.

Thanks to flexible design options in terms of colour and size, the windows could be planned to match the

interior and exterior, creating seamless transitions between the indoor and outdoor space. Subtle-grey window profiles perfectly blend into the clear design line, creating a perfect harmony with the oak floorboards that connect the rooms in the basement and underline the spacious interior design.

The window system heroal W 72 also blends in perfectly with the building's façade. While the basement is completely clad in local greywackes, which are also used as flooring on the patio, the upper white plastered part of the house looks as if it is supported by natural stone columns. The contrast of colours and materials makes it appear to float above the slope. The generous glass surfaces of the windows, which are arranged harmoniously across the side facing the valley, cleverly break up the look of the natural stone cladding and thus provide for special accentuations, especially when the rooms are lit up in the evening. The floor-to-ceiling windows also serve as patio doors and allow direct access to the garden.

heroal front door system in spacious entrance area

The entrance area of the villa is set back, visually shielded from the street by the adjacent garage front and the overhanging roof. Nevertheless, the modern front door from the heroal D 72 door system and the sidelights with large glass surfaces make it appear bright and welcoming. This is not only where guests are invited to come in, it is also the central access to the common rooms as well as the parents' area with master bedroom, dressing room and separate bathroom.



In addition to a pleasant welcome, the large glass surfaces allow for plenty of daylight in the interior. The aluminium profiles of the sidelights and the heroal D 72 front door are perfectly matched to the window system heroal W 72 and



the lifting-sliding system heroal S 77 SL. Due to the identical face widths of the elements and the uniform colour design in RAL 9006, the door and window systems appear to be cast from a single mould. The colour intensity is retained for decades, thanks to the particularly durable, highly weather-resistant and UV-resistant heroal hwr powder coating. The front door system heroal D 72 also impresses with its durability, high burglary protection, sound insulation, and excellent thermal efficiency.

heroal lifting-sliding door system reduces boundaries between rooms

A large lifting-sliding door leads from the living room to the adjoining patio with a view of the landscape. The barrier-free lifting-sliding system heroal S 77 SL fulfils the structural requirements, is easy to operate even with large elements, and creates ample transparency. The frameless fixed glazing in combination with the movable monorail sash makes the lifting-sliding door the perfect link between interior and exterior. When open, the door smoothly extends the living space to the outside. On warm days, the builder-owners enjoy the time on their covered patio.

"Our aspiration for the project was to plan a modern home with a high technical and design standard that combines all our wishes while perfectly incorporating the local surroundings," reports the owner. "When choosing the windows, doors and lifting-sliding doors, we were totally convinced by the subtle design and the flexibility of heroal systems. The windows could be matched exactly to our needs in terms of colour, size and function."

Project information

- » building owner: the G. family
- » planning / architects: oxen architekten, Cologne
- » fabricator: Brandenstein GmbH
- » year of completion: 2018

heroal systems

- » heroal W 72 window system
- » heroal S 77 SL lifting-sliding door system
- » heroal D 72 door system

Hotel & Residential: Berghotel Rudolfshütte

Uttendorf, Austria

- » heroal W 72 window system
- » heroal D 72 door system
- » fabricator: alu-one Metallbaupartner GmbH



Hotel & Residential: Holiday house

Rügen island, Germany

- » heroal W 72 window system
- » heroal S 77 SL lifting-sliding system
- » heroal IS insect screen
- » fabricator: Andreas Walraph Metallbau



Hotel & Residential: Vila Koloděje

Prague, Czech Republic

- » heroal W 72 window system
- » heroal S 77 SL lifting-sliding system
- » fabricator: JIS s.r.o.



Hotel & Residential: Seaside villa

France

- » heroal W 72 window system
- » heroal S 77 SL lifting-sliding system
- » fabricator: Armoral Menuiserie Aluminium





Hotel & Residential: Villa Luc Saey

Sint-Martens-Latem, Belgium

Read project
report online

Inspiration from nature

The one-family home skilfully combines and reflects the colours and designs of its natural surroundings. In addition to the elegant, large heroal sliding doors, the architect paid special attention to the windows and their details: the aluminium windows made by heroal were installed in wooden frames. This combination is only one of the many exciting contrasts you can find in this building. The overall impression is a Frisian villa that perfectly blends in with the setting, from its reed roof to its window details. Thanks to the large glass surfaces and the use of aluminium, traditional and modern design elements merge in a unique and appealing way.

coated in RAL 9005 deep black with a fine structure, gives them a distinctive and at the same time subtle look. Another important focus was placed on the robustness of all building parts, given that the house is located near a lake. As an official GSB-Premium-Coater awarded with the quality seal „Approved Premium Coater – Sea Proof“, heroal offers systems that are very durable even under extreme conditions: our tried and tested highly weather resistant heroal hwr powder coating makes our window systems resistant against the sometimes rough weather conditions in East Flanders.

heroal sliding door systems: for comfort and design, inside and outside

For three large opening elements, the owner chose the aluminium lifting-sliding door system heroal S 77. It meets highest demands on constructional design, is easy to use and represents the ideal combination with the selected window system heroal W 72 CW. With open doors, the living space extends to the landscape beyond. Together with the 20 windows of the house, the closed doors provide for rooms flooded with light even in winter.



heroal window systems: bar by bar individual design

The owner of the building opted for custom-made windows from the window system heroal W 72 CW, which is both functional and flexible. Made from high-quality aluminium, they meet all demands on efficiency, sustainability and sophisticated design. These windows take up the customary lattice window design typical of the region and thus perfectly match the architectural style of the house. The noble colour of the sashes and frames,



Project information

- » building owner: Luc Saey
- » planning / architects: Sandra Schepers
- » fabricator: Timmerman Productie NV
- » year of completion: 2018

heroal systems

- » heroal W 72 CW window system
- » heroal S 77 lifting-sliding system

Hotel & Residential: Joylife Boats Houseboats

Mettlach, Germany

- » heroal W 72 window system
- » heroal S 42 sliding door system

- » fabricator: Klein Metallbau GmbH



Read project
report online



Hotel & Residential: Single-family house

Haan, Germany

- » heroal C 50 HI curtain wall system
- » heroal W 72 window system
- » heroal D 92 UD door system

- » fabricator: Wigger Fenster + Fassaden GmbH





Industry & Trade: Pergande Group

Südliches Anhalt, Germany

- » heroal C 50 curtain wall system
- » heroal W 72 and heroal W 50 window systems
- » heroal D 72 door system

- » fabricator: Köhler-Aluglasbau GmbH



Industry & Trade: ovesco Endoskopy AG

Tübingen, Germany

- » heroal W 72 window system
- » heroal VS Z sun protection system

- » fabricator: epplerfenster GmbH & Co.KG





Read project report online

Industry & Trade: Revaler Spitze commercial complex

Berlin, Germany

Aluminium system solutions for urban industry architecture

By mid-2021, after completion of two construction phases, the project "Revaler Spitze" will have created a flexibly useable office and commercial space in the heart of Berlin Friedrichshain. At this top location, a great number of start-ups and traditional businesses will be united under one roof, occupying a gigantic space of 17,300 square metres. The building on Revaler Street has been named after its characteristic wedge shape, resembling a tip or "Spitze". The architectural look, with its classic red-brick façade and steel profile frames, is borrowed from the architecture of the early 20th century. The heroal system solutions for curtain walls, windows and doors installed here further underline the industrial charm of the building and also make a significant contribution to put the idea of sustainability this project pursues into effect.

Fresh breeze for working at the speed of life

Flexibly useable commercial space, offering aesthetic looks and functionality and a central location: still a genuine rarity in Berlin. The appeal of the building also results from its location in Friedrichshain, in the heart of Berlin. Here, the intercultural creative scene and the good mix of start-ups and traditional businesses provide for a fresh breeze blowing through entrepreneurial thinking.

The "Revaler Spitze" offers plenty of space for creative exchange, inspiration and a contemporary way of working - from the smallest planned retail space of 202 square metres to the sophisticated room concept on up to



3,000 square metres covering two floors. Furthermore, all tenants may use 548 square metres of beautifully designed outside space in the surrounding courtyards and on the roof terrace – a fantastic view of Berlin included.

Flexible curtain wall system by heroal for an impressive building shell

Including the completion of the second construction phase in June 2021, approximately 620 heroal systems will have been installed in the "Revaler Spitze".



Hence they shape the view of the new building to a great extent. In close cooperation with the builder owner, the contractor, the window company Wagner, chose the curtain wall system heroal C 50. This curtain wall system combines sustainable construction with freedom of design. Through innovative design details, heroal C50 offers a filigree look while at the same time achieving excellent heat insulation values, which, with a building of this size, lead to considerable savings of energy and costs, and have a positive effect on the energy balance. The individually designed curtain wall system grants the building shell an impressive character: derived from the steel profile frame look of the early 20th century, the curtain wall system has an anthracite grey heroal hwr powder coating that further underlines the industrial charm of the building.

heroal window systems: equally sustainable and appealing

The windows of the "Revaler Spitze" are also supplied by the company heroal. As all other heroal systems, the window system W 72 is made from recycled aluminium and, thanks to innovative design details, provides optimal protection against loss of energy. Hence, this heroal window system is the best choice for a contemporary commercial project. At the same time, it meets the building owner's demands for an architectural look in every respect: industrial architecture and the anthracite grey aluminium systems are a perfect match. In order to put a special accentuation on the depth of the windows, static cross bars are used for the "Revaler Spitze". To achieve

this effect, heroal manufactures special profiles especially for the reveals of this project, which aesthetically and functionally enclose the cross bars.

Inviting outside, flooded with light inside

At the entrances to the building, generously designed doors from the project door system heroal D 72 welcome tenants, visitors and customers to the "Revaler Spitze". The large glass surfaces provide for a pleasant reception and plenty of daylight in the interior space. In addition to extremely high heat insulation values and an increased protection against burglary and noise, this door system is noted for a long durability and hence is ideally suited for the highly frequented foyers and entrance areas of a building.



Project information

- » building owner: VARENTA Holding GmbH
- » planning / architects: VARENTA Holding GmbH, Gero Diercks and Christian Schönberger
- » fabricator: Schreinerei&Metallbau Wagner GmbH
- » year of completion: 2021

heroal systems

- » heroal C 50 curtain wall system
- » heroal W 72 window system
- » heroal D 72 door system



Industry & Trade: Les Cafés SATI

Strasbourg, France

- » heroal W 72 i window system
- » heroal D 72 door system
- » fabricator: ATALU SAS



Industry & Trade: SiSi-Werke GmbH

Eppelheim, Germany

- » heroal C 50 curtain wall system
- » heroal W 72 window system
- » heroal profile bending and sheet metal processing





Read project report online

Industry & Trade: Stelling Höfe

Hamburg, Germany

heroal Project Service provides support for architects and fabricators

Various shops are now located on the Stelling Höfe site on Kieler Straße in Hamburg, Germany, for serving local people. The former tram depot has undergone extensive renovation and has been extended with new buildings. heroal Project Service was involved in this new building project, supporting the engineering company Mennerich – heroal helped in planning the systems installed and preparing the service specifications, for example. heroal also assisted the fabricator Hilgefert & Götting Metall- und Fensterbau in quotation pricing.

Commercial building with historic charme

The Stelling Höfe complex consists of a total of eight buildings or parts of buildings, some of which are connected to each other. The popular shopping, sports and leisure location was acquired by an investor in 2015 and has now been comprehensively renovated and extended. Two new buildings were equipped with heroal systems. Among other systems, the curtain wall system heroal C 50, the window system heroal W 72 i, the project door system heroal D 72 as well as the sun protection system heroal VS Z were installed.

With their combination of masonry and steelwork, the two new buildings are reminiscent of the old times, when the site was used as a railway and tram depot. Now it is used for commercial and office properties, the combination blends perfectly with the surroundings in the immediate vicinity of the German rail freight line. The heroal aluminium systems match the architects' concept perfectly: A fine reproduction of the desired steel look, thanks to the wide range of colours including more than 500 RAL, DB and VEKA shades. For a perfectly colour-coordinated



look, all the heroal systems installed were coated with the highly weather resistant heroal hwr powder coating in the colour black grey metallic with fine structure (heroal colour code: 0794). The chosen colour works well with the brick façade, creating an industrial look and harmonious appearance of the entire building shell.

All-round support from heroal Project Service

To ensure a smooth coordination during the project planning phase, heroal Project Service supported the architects with individual design ideas and created the service specifications using standard tender texts, for example.

As the heroal Project Service employees know the capacities and competences of the heroal fabricators, they were able to assist in a timely and fair placement of orders. Thanks to the digitally provided material calculation, potential fabricators were able to import the data directly into their calculation software, prepare an estimate without much effort and submit an offer promptly. In the end, the contract was awarded to the company Hilgefert & Götting Metall- und Fensterbau GmbH. "Our support with quotation pricing accelerates and simplifies the quotation process enormously. Thanks to the precise planning in advance, and a detailed material list, the quotations submitted by the fabricators include all required materials. This means all quotations can be perfectly compared with each other with no recalculations necessary," says Ronny Symannek, Head of Project Service & Quotation Centre at heroal.

heroal systems: Individually planned and perfectly coordinated

The buildings offer space for three supermarkets and a bakery, among other facilities. The front of one supermarket consists of a large glass façade, which creates a bright, transparent and welcoming retail area. heroal Project Service provided the static pre-dimensioning for the mullion-transom curtain wall heroal C 50 installed, determined the design depths of the curtain wall profiles and used these for the construction drawing that was then submitted as a design proposal. Thanks to the modular system design of the curtain wall heroal C 50, the profiles have a uniform face width of 50 cm, independent of the design depths. As a result, the entire building is in harmony – even with different requirements on thermal insulation and fire protection.

The mullion-transom curtain wall heroal C 50 has also been used for additional parts of the project, and then further equipped with insert elements, such as the block window system heroal W 72 i and the commercial door system heroal D 72, as well as the curtain wall canopy heroal C 50 TC.

Project information

- » proprietor: GSG Stelling Hof mbH
- » architects: Mennerich BauProjektManagement GmbH
- » fabricator: Hilgefert & Götting Metall- und Fensterbau GmbH
- » year of completion: 2020/2021



As a protection against direct sunlight, the sun protection system heroal VS Z has been installed, this time as a partly integrated variant. Whereas the panel boxes are integrated in the brickwork and invisible from the outside, the visible guide rails, end strips and textile screens are colour-coordinated with the curtain wall system heroal C 50. The sun protection system heroal VS Z is also suited for shading large glass surfaces, offering ideal protection against glaring light, prying eyes and UV radiation, while at the same time providing for the required stability in strong winds. During the hot summer months, heroal VS Z prevents the buildings from heating up, and has a positive impact on the energy balance.



"heroal Project Service also made a significant contribution to ensuring that the building project ran smoothly during every project phase, and helped it to be carried out in an efficient way. We do not only support the architects, fabricators and builders involved in a project, but also see ourselves as a network connecting the individual parties. By providing personal advice at all times and supporting the individual project phase, we are able to react to every situation and find perfect solutions for every building project – no matter whether the projects require standard or special solutions," summarises Ronny Symannek the tasks of heroal Project Service.

heroal systems

- » heroal C 50 curtain wall system
- » heroal W 72 i window system
- » heroal D 72 door system
- » heroal VS Z sun protection system
- » heroal C 50 TC canopy system



Industry & Trade: Assembly hall with office building

Rheinau, Germany

- » heroal W 72 window system
- » heroal D 72 door system
- » heroal SD Surface Design

- » fabricator: Berma Glaserei Fensterbau GmbH

Industry & Trade: Autohaus Mercedes Beineke

Holzminden, Germany

- » heroal C 50 curtain wall system
- » heroal W 72 window system
- » heroal D 72 door system

- » fabricator: Kleinschmidt GmbH & Co.KG Metallbau





Industry & Trade: Fire brigade and fire engine house

Kaunitz, Germany

- » heroal D 82 FP fire protection door system
- » heroal W 72 window system
- » heroal D 72 door system

» fabricator: Metallbau Funke GmbH & Co. KG

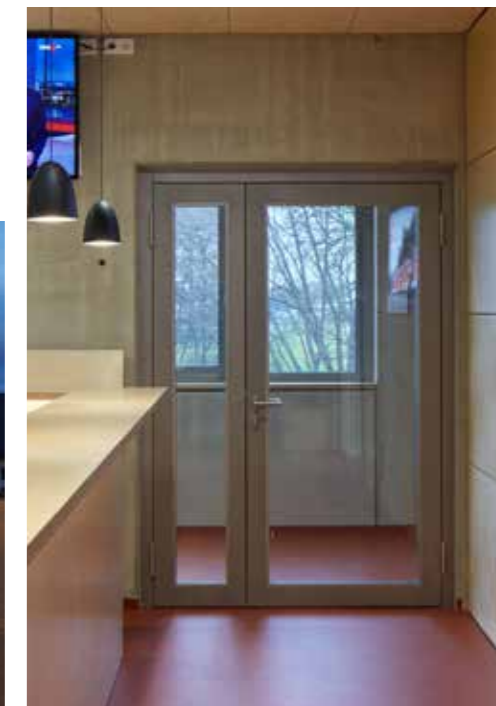

Industry & Trade: Mühlencafé Ottendorf

Ottendorf-Okrilla, Germany

- » heroal C 50 curtain wall system
- » heroal W 72 window system
- » heroal D 72 door system

» fabricator: Köhler Aluglasbau





Culture & Entertainment: Glück Auf indoor swimming pool

Zwickau, Germany

- » heroal C 50 HI curtain wall system
- » heroal W 72 window system
- » heroal D 72 door system
- » heroal D 65 C SP non-insulated smoke protection door system

» fabricator: Döhler & Tietze GmbH



Culture & Entertainment: Art museum

Bochum, Germany

- » heroal D 82 FP fire protection door system
- » heroal W 72 RL window system
- » heroal profile bending service for arched windows
- » special requirements due to the building being listed

» fabricator: Jürgen Kirstein GmbH Feineisen und Metallbau & Ingenieurbüro mltechnik
Alexander Schraven





Read project report online

With project-specific testing Hotel & Residential: Residence Garden Towers

Prague, Czech Republic

Urban Flair of the Residence Garden Towers

In 2017, the residential construction project Residence Garden Towers was completed in Zizkov, a popular and fashionable district close to Prague city centre. Its unique design ensures that the building fits in perfectly with the urban district: the lower of the 21 storeys were built on an almost square base, from which five towers rise up nearly 55 metres into the air. From the very top floors, residents are offered a spectacular view of Prague's old town and the castle. Alongside the metropolitan flair, a unique system of roof gardens and terraces as well as the landscaped courtyard with a children's playground provide residents with exclusive quiet zones for additional comfort and enjoyment.

Comfort and Enjoyment Across 21 Storeys

The lower storeys are designed as commercial units, while the remaining approximately 630 units offer residential space for up to 1,400 people – from one-room flats to spacious four-room apartments. All apartments feature modern and high-quality fittings, including aluminium window systems from heroal, as well as luxurious bathrooms, wooden floors and "smart living" options. The environmental footprint of the material aluminium is also a central sustainability factor. The energy-efficiency of the installed elements with reduced material use is also taken into consideration: heroal uses up to 85% recycled aluminium in the production

of the complete system portfolio, ranging from windows, doors and curtain walls to roller shutters, sun protection and roller doors. That way, 95% less energy is used compared to using newly produced aluminium, without any loss of quality. Aluminium systems are quite durable. This is due to their high weather resist-



ance, natural protection against corrosion as well as high material stability. Even when opened and closed a multitude of times, there is minimal wear and tear.

Equipped with heroal systems all around

Metal processor SLOVAKTUAL s. r. o. relied on the outstanding quality of heroal's aluminium profile systems when constructing the Residence Garden Towers. Around 3,000 elements of the window system heroal W 72 were used in the entire building. These were subject to extensive testing in advance in the heroal in-house test stand, which is certified by ift Rosenheim.

As standard, the window system fulfils the high technical requirements of the developer:

- » soundproofing of 45 dB
- » class 9A resistance to driving rain
- » class C3/B3 wind resistance
- » class 4 air permeability

The commercial units on the ground floor were fitted with heroal C 50 façade in a transom-mullion construction. The system meets highest standards in terms of

effective heat insulation combined with narrow profile face widths of 50 millimetres – large glass surfaces and high transparency could thus be realised without any problems. The door system heroal D 72 is ideally suited for heavily frequented areas – a worthwhile investment for one of the largest residential construction projects in Prague.



Project information

- » project: Residence Garden Towers
- » building owner: Central Group a. s.
- » planning / architects: Central Group a. s.
- » fabricator: SLOVAKTUAL s. r. o.
- » year of completion: 2017

heroal systems and services

- » heroal W 72 window system
- » heroal S 77 lifting-sliding system
- » heroal D 72 door system
- » support with calculation
- » production support from heroal application engineers
- » project-specific testing

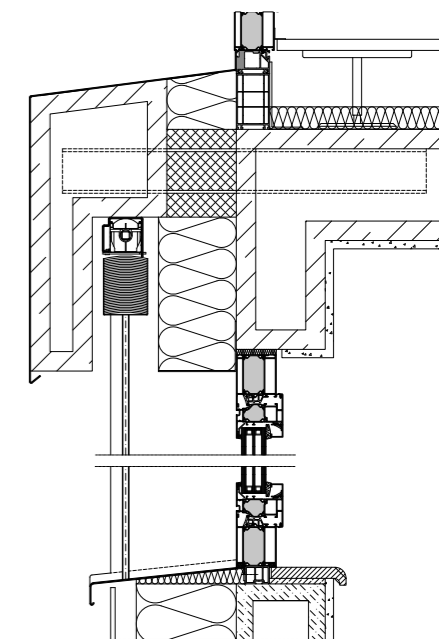
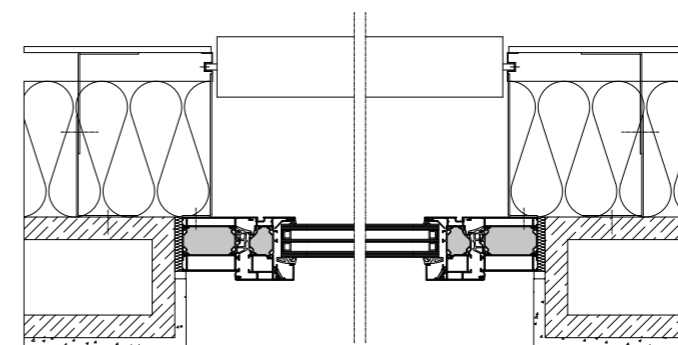



Scan and view film

Special solution: V-Tower

Prague, Czech Republic

The V-Tower Prague is one of the Czech Republic's most exclusive high-rise buildings

Located in the popular mixed residential and commercial Pankrac district, south of Prague's historical centre, the V-Tower's construction will be completed in 2017. Offering 120 apartments on 30 floors, the 104-metre-high residential complex already counts among the most select high-rises in the Czech Republic.

An exclusive building shell – thanks to heroal “made in Germany” quality

In order to underline the symbolism of “V”, particular emphasis was given to transparency. This goal was achieved, using over 1,700 sophisticated, production-optimised heroal elements from the heroal S 77 SL lifting-sliding system and the heroal W 72 window system. Since numerous custom-made units were required, due to both form and dimensions, and stringent demands for quality, design and technical detail had to be adhered to, the Sipral a.s. metalworking company made a conscious choice for heroal as a system supplier: “Not every manufacturer in the segment has the capacity to reliably

realise such complicated projects, or to satisfy our stringent requirements. For this reason, we made a deliberate choice for the innovative family-owned heroal company, which provides outstanding “made in Germany” quality,” says Leopold Bares, Chairman at the Czech company Sipral a. s. According to him, heroal is the sole manufacturer in the sector to have its own, in-house, state-of-the-art bending and folding service. Additionally, heroal's in-house, highly weather resistant surface coating ensures long-term, top-quality colour stability, gloss retention and durability against weathering. Particular attention was paid to technical aspects - given the unusual design and the building's height, construction had to achieve specified wind load resistance rating class C3 and water tightness 8A. Windows and lifting-sliding elements were also required to achieve a noise insulation rating of up to 39 dB, thermal insulation of 1.5 W/m²K, and class 4 air permeability. This posed no problem for heroal – the heroal W 72 and heroal S 77 SL systems exceed these requirements.

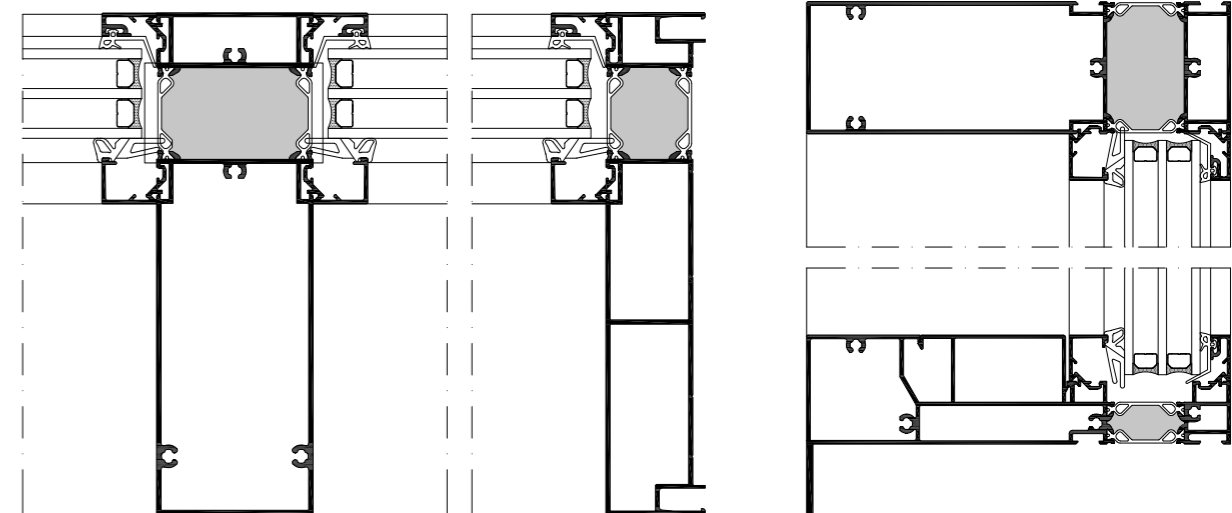
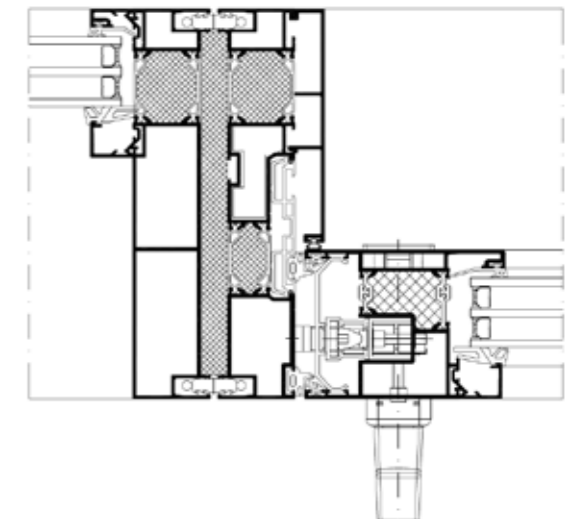

Project information

- » building owner: PSJ INVEST, a. s.
- » planning / architects: Radan Hubička Architectural Studio
- » fabricator: Sipral a. s.
- » year of completion: 2017

heroal systems and services

- » heroal W 72 window system
- » heroal S 77 SL lifting-sliding system
- » development of project profiles
- » development of expansion frame construction
- » development of crossbar profiles
- » development / optimization of installation and structural attachments
- » project-specific packing sizes
- » development of insert frame design in heroal S 77 SL
- » project-specific verification from ift Rosenheim



Read project report online

Green Good Design Award

For their realisation of the AFI Vokovice project in Prague, heroal received the Green Good Design Award in 2019. The Green Good Design Award is among the Good Design Awards founded in 1950 and is presented every year. Jury members consisting of renowned designers, architects and journalists select projects, products, technologies and concepts which follow an outstanding idea of sustainability.

Project information

- » building owner: AFI Europe
- » planning / architects: Architekturbüro DAM
- » fabricator: Sipral a. s.
- » year of completion: 2018

heroal systems

- » heroal C 50 curtain wall system
- » heroal W 72 window system
- » heroal W 72 VF ventilation flap
- » heroal VS Z sun protection systems
- » heroal D 72 door system
- » unitised curtain wall as special design

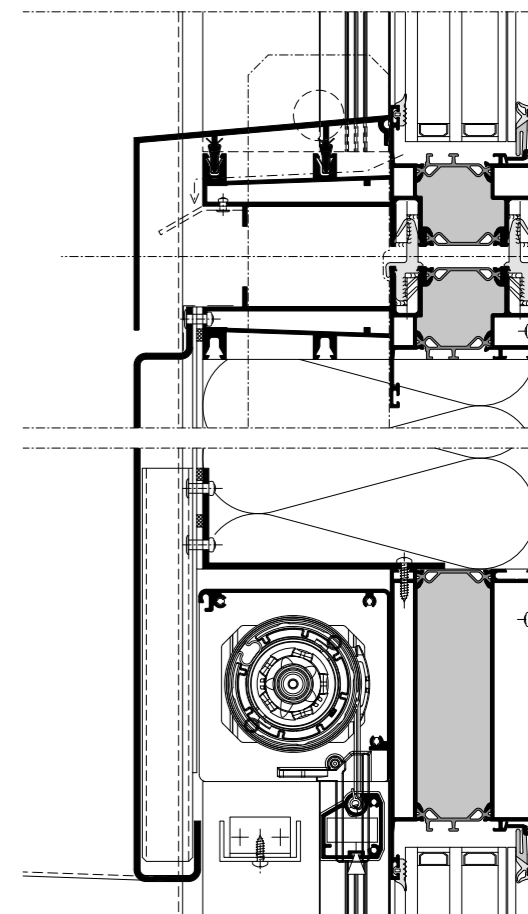

Special solution: AFI Vokovice

Prague, Czech Republic

AFI Vokovice stands out with modern architecture

As a real estate and investment company, AFI Europe focuses on the development of large-scale commercial projects as well as residential buildings in Central and Eastern Europe. In mid-2018, the modern building complex AFI Vokovice in Prague was completed – an object built for the future with heroal systems. This building aimed at and in fact achieved the LEED Platinum certification, not least thanks to the material used. Aspects such as energy-efficiency and sustainability are of special significance in this project.

Equipped with heroal systems all around

Both building parts are furnished with aluminium products of the highest quality, including almost 30 heroal D 72 door system elements and the heroal C 50 HI façade around the shopping arcade on the ground floor, and also approx. 1,000 object-specific heroal W 72 window system profiles. More than 600 heroal W 72 VF ventilation flaps provide fresh air even at great heights - and all that with a homogenous façade design. This is because the heroal W 72 VF ventilation flap makes an anti-drop device superfluous thanks to its small aperture width.

Furthermore, over 800 heroal VS Z sun protection system elements were integrated into the window modules. The heroal Zip-Screen system consists of translucent fabric which is installed in front of the window. By reflecting the sunlight, the system reduces the solar radiation by up to 75% without loss of natural sunlight. That way, the system guarantees a pleasant climate on hot days and allows for regulation of room atmosphere. At the same time, heroal VS Z provides optimal glare, screen and heat protection. The sun protection system saves cooling and heating costs compared to traditional thermal insulation glazing, as the heat transfer can be controlled as needed. At the same time, UV radiation is filtered by up to 98%.

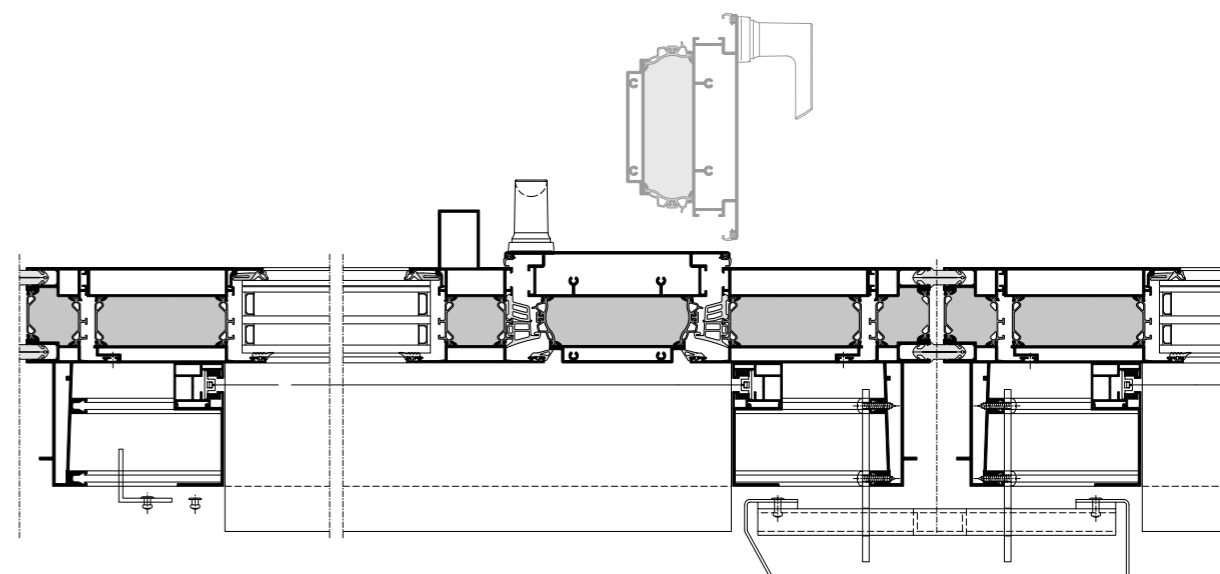



Scan and view film

Special solution: Tour Elithis Danube

Strasbourg, France

Positive energy balance in the Tour Elithis Danube

A base area of 554 square metres, 17 floors with 60 flats, 900 square metres of office space and a roof terrace at a height of about 50 metres result in a total usable floor space of 4,500 square metres - this would be one way to describe the Tour Elithis Danube. Another would be to say that the high-quality sheet-metal cassette curtain wall elements sparkle in the sun. But beside all these facts and external elements, energy efficiency plays the most important role in the Tour Elithis Danube. Because one of the key goals was to construct a residential tower that produces all the energy it needs (zero power calculation). Thanks to its optimal facilities, the Elithis Tower even produces slightly more energy than is actually required: the building is aerodynamically constructed and has a highly insulating curtain wall.

Both the roof and the south-facing curtain wall are equipped with a photovoltaic plant covering total of 1,233 square metres. The window and lifting-sliding door elements are made of aluminium and also have a highly insulating effect. These and other measures were important to the Elithis SAS engineering group, because it was their aim to make residents more aware of the principle of energy saving in everyday life. They wanted to show that living comfort is not achieved through energy waste.

The generated energy is equitably distributed to the residents of the house; any surpluses are fed into the grid. The energy consumption can be monitored on specially installed screens. Residents who consume very little power can even earn a bonus on their bills for the first six years. As a result, it is also possible to present the Tour Elithis Danube as a genuine living concept of the future.

heroyal systems for more energy efficiency

The metal works were carried out by the French metal construction company ATALU SAS. The aluminium systems supplier heroyal supplied the system "The demands on building shells have dramatically increased in recent years. Modern, future-oriented projects such as the Elithis Tower place the highest demands on heat insulation, aesthetics and workmanship. These can only be achieved through strong partnerships," says Julien Rohmer, Managing Director of ATALU SAS.

Almost 300 elements of the heroyal W 72 window system were used in the sheet-metal cassette curtain wall. Especially narrow view widths were important to the property developer - an individually adapted solution that blends in perfectly with the building shell. Thanks to highly thermally insulated composite profiles made of aluminium half-shells, polyamide insulating webs and

a completely foamed insulation zone, the heroyal W 72 window system achieves a Uf value of up to 0.93 W/m²K with a frame depth of just 72 mm. At the same time, the innovative web geometry makes the time-consuming and material-intensive use of frame and glazing rebate insulation unnecessary. The modular design leads to an optimal use of energy and materials and thus to maximum energy efficiency throughout the entire useful

life. In order to offer the residents a special view of the newly landscaped harbour district, the roof terrace was also equipped with large glazed areas. 30 lifting-sliding elements of the heroyal S 77 SL system were installed here.

Project information

- » building owner: Elithis SAS
- » planning / architects: cabinet X-TU
- » fabricator: ATALU SAS
- » year of completion: 2018

heroyal systems

- » heroyal W 72 window system
- » heroyal S 77 SL lifting-sliding system
- » implementation using special profiles



heroal Project Services. Support in all work phases.



Scan to
contact us

Expertise and customer proximity are our strengths. Let our heroal architectural consultants throughout Germany advise you – if necessary right at your construction site. In addition, our technical support team will assist you with any questions you may have about windows, doors, sliding doors, curtain walls, roller shutters, sun protection, roller doors and roofing.

Feel free to contact us today:
» www.heroal.de/en/architects/contact-form
» + 49 5246 507-5156
» info@heroal.com

You are also invited to discover our Architects area at www.heroal.de/en/architects

Or follow us on LinkedIn:



Photo credits

- | | |
|---|--|
| » page 100 Fritz-Henßler Berufskolleg | Photos: Jörg Hempel Fotografie |
| » page 106 PhoenixWERK | Photos: Christian Eblenkamp |
| » page 110 Kotelna Park II | Photos: Štěpán Látal |
| » page 113 IT Campus | LIRA - Heine Warnecke Design |
| » page 122 G. residence | Photos: Stefan Schilling |
| » page 125 Holiday home in Rügen | Photos: DOMUSimages, Peggy Kastl (architect) |
| » page 126 Vila Koloděje | Photos: Volny |
| » page 127 Seaside villa | Photos: Armoral |
| » page 129 Villa Luc Saey | Photos: Timmerman Productie NV |
| » page 134 Revaler Spitze | VARENTA Holding GmbH |
| » page 140 Mercedes Beineke | Photos: www.PHOMAX.de |
| » page 143 Verl fire brigade, Kaunitz fire engine house | Photos: Csaba Mester Fotografie |
| » page 152 Tour Elithis Danube | Groupe ELITHIS |

Photo credits for all other project photos are held by heroal.





Roller shutters | Sun protection | Roller doors | Windows | Doors | Sliding doors | Curtain walls | Roofing

heroal – Johann Henkenjohann GmbH & Co. KG

Österwieher Str. 80 | 33415 Verl (Germany) | Tel. +49 5246 507-0 | Fax +49 5246 507-222 | www.heroal.com